

---

# Table of contents

	<b>Resources</b>	<b>3</b>
<b>1</b>	<b>Introduction</b> <i>Koeno Gravemeijer</i>	<b>5</b>
<b>2</b>	<b>Jumping ahead</b> <i>Julie Menne</i>	<b>9</b>
	2.1 Introduction	9
	2.2 Framework	11
	2.3 Description of the productive training program	14
	2.4 Development of the productive training program	16
	2.5 Results	19
<b>3</b>	<b>Teaching formal mathematics in primary education</b> <i>Ronald Keijzer</i>	<b>25</b>
	3.1 Mathematising in Realistic Mathematics Education	25
	3.2 Fraction learning	26
	3.3 Research questions and hypothesis	26
	3.4 Methods	27
	3.5 Research setting	29
	3.6 Results	30
	3.7 Fraction learning processes	31
	3.8 Conclusion	32
<b>4</b>	<b>If you know what I mean</b> <i>Corine van den Boer</i>	<b>35</b>
	4.1 Motivation for the research	35
	4.2 Formulating the first research questions	36
	4.3 Description of the data collection	37
	4.4 The research process illustrated	39
	4.5 Answering the research questions	41
	4.6 If you know what I mean	46
<b>5</b>	<b>Reinvention of early algebra</b> <i>Barbara van Amerom</i>	<b>47</b>
	5.1 Introduction and research problem	47
	5.2 Problems of learning algebra	47
	5.3 The history of algebra	49
	5.4 Research design and methodology	50
	5.5 Design of the learning trajectory	52
	5.6 Results	53
	5.7 Discussion and recommendations	56

---

<b>6</b>	<b>Design research in statistics education</b>	<b>61</b>
	<i>Arthur Bakker</i>	
6.1	Introduction	61
6.2	Background and research questions	62
6.3	Methodology	63
6.4	Historical phenomenology	64
6.5	Exploratory interviews and a didactical phenomenology	65
6.6	Designing a hypothetical learning trajectory for grade 7	65
6.7	Answer to the first research question	66
6.8	Answer to the second research question	71
6.9	Answer to the integrated research question	74
6.10	Symbolizing	79
6.11	Computer tools	80
<b>7</b>	<b>Learning algebra in a computer algebra environment</b>	<b>83</b>
	<i>Paul Drijvers</i>	
7.1	Research questions	83
7.2	Theoretical framework	84
7.3	Analysis of the concept of parameter	86
7.4	The instrumental approach to using computer algebra	88
7.5	Methodology	90
7.6	Through the research cycles	92
7.7	Results on computer algebra use and the concept of parameter	95
7.8	Results concerning the instrumentation of computer algebra	97
7.9	CAS use and the learning of algebra in general	99
<b>8</b>	<b>A Gateway to Numeracy</b>	<b>105</b>
	<i>Mieke van Groenestijn</i>	
8.1	Background Information	105
8.2	Research Questions	106
8.3	Setting	107
8.4	Characteristics of this Study	108
8.5	Conclusions and Discussion	108
8.6	Recommendations for Future Research	119
8.7	Concluding	121

---

## Resources

The chapters of this book are based on the following doctoral theses:

- Chapter 2:  
Menne, J.J.M. (2001). *Met sprongen vooruit. Productief oefenen: een programma voor zwakke rekenaars in het getallengebied tot 100 - een onderwijsexperiment*. Utrecht, the Netherlands: CD-β Press. Supervisor: Prof.dr. A. Treffers.
- Chapter 3:  
Keijzer, R. (2003). *Teaching formal mathematics in primary education*. Utrecht, the Netherlands: CD-β Press. Supervisor: Prof.dr. J. Terwel.
- Chapter 4:  
Boer, C.J.E.M. van den (2003). *Als je begrijpt wat ik bedoel. Een zoektocht naar verklaringen voor achterblijvende prestaties van allochtone leerlingen in het wiskundeonderwijs*. Utrecht, the Netherlands: CD-β Press. Supervisors: Prof.dr. K.P.E. Gravemeijer & Prof.dr. J. de Lange.
- Chapter 5:  
Amerom, B. van (2002). *Reinvention of early algebra*. Utrecht, the Netherlands: CD-β Press. Supervisors: Prof.dr. J. J. de Lange, Prof.dr. K. P.E. Gravemeijer & Dr. J.A. van Maanen.
- Chapter 6:  
Bakker, A. (2004). *Design research in statistics education. On Symbolizing and computer tools*. Utrecht, the Netherlands: CD-β Press. Supervisors: Prof.dr. K.P.E. Gravemeijer, Prof.dr. G. Kanselaar & Prof.dr. J. de Lange.
- Chapter 7:  
Drijvers, P.H.M. (2003). *Learning algebra in a computer algebra environment, design research on the understanding of the concept of parameter*. Utrecht, the Netherlands: CD-β Press. Supervisors: Prof.dr. K.P.E. Gravemeijer & Prof.dr. J. de Lange.
- Chapter 8:  
Groenestijn, M. van (2002). *A Gateway to Numeracy. A Study of Numeracy in Adult Basic Education*. Utrecht, the Netherlands: CD-β Press. Supervisors: Prof.dr. K.P.E. Gravemeijer & Dr. I. Gal.

---

---

# 1 Introduction

*Koeno Gravemeijer, Research Coordinator of the Freudenthal Institute*

In this booklet we have brought together summaries of a series of doctoral studies on realistic mathematics education (RME), carried out at the Freudenthal Institute or by researchers affiliated to the Freudenthal Institute. Together, these give an impression of the classroom-based work of the institute, even though doctoral research is only part of the research done at the institute.

The institute has a dual task of both fostering the improvement of mathematics education in schools, and researching mathematics education. On the one hand, the institute acts as a national expert center for mathematics education; as such, it plays a central role in the innovation of mathematics education in schools by developing instructional materials, theories and curricula that are shared with a lively network of teachers, teacher educators, schoolbook authors, school councilors, researchers, and others via meetings, conferences, journals and internet. On the other hand, the institute is also a university-based research institute.

To facilitate the connection between innovation and research, the research is tailored to practical use. In this respect, the institute's research can best be characterized by what Stokes (1997) calls 'Pasteur's Quadrant'. Stokes categorizes research on two dimensions: consideration of use, and a quest for fundamental understanding (Fig. 1.1). Like Pasteur's research, the research of the Freudenthal Institute fits the category of research that pairs a quest for understanding with considerations of use.

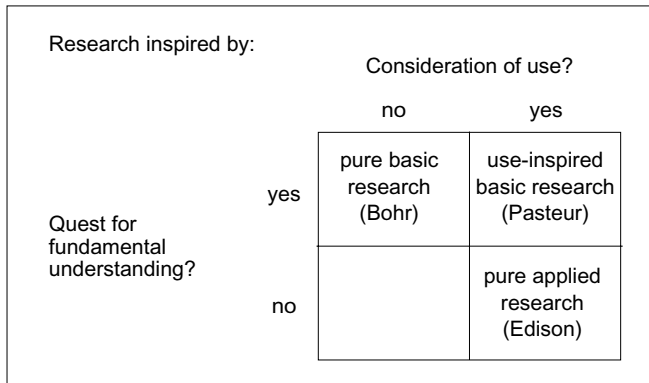

Figure 1.1: Quadrant model of Scientific Research (Stokes, 1997, p. 73)

Most of the institute's research has the character of design research (also referred to as design experiments, or developmental research). The main research goal is to develop a domain-specific instruction theory for realistic mathematics education.

Here Freudenthal's ideal of 'mathematics as a human activity' is taken as a starting point. Design experiments are used to develop instruction theories that constitute mathematics education that is consonant with the ideal of mathematics as a human activity. The yield of a single design experiment is a local (i.e. a topic-specific) instruction theory. A collection of local instruction theories lays the basis for a more encompassing domain-specific instruction theory, which is teased out by generalizing over various local instruction theories. The domain-specific theory in turn feeds back into the development of local instruction theories. Note that those theories are dynamic, open to change. New societal demands, new technological developments, or focus on specific groups of students, for instance, may create the need for adjustments, which again will be pursued via developmental research.

This openness to change and variation is also reflected in the examples in this booklet. Keijzer's research (Chapter 3), for instance, offers an alternative to the local instruction theory on fractions developed by Streefland (1991). Further, Menne's study on a training program for mental calculation with numbers up to 100 (Chapter 2) offers a variant of the use of the empty number line, tailored to weaker students, which differs substantially from an alternative approach based on measuring (Stephan, Bowers, Cobb & Gravemeijer, 2003). In a similar manner, Van Groenestijn (Chapter 8) investigates how RME can be made to fit the specific requirements of adult education.

To some extent, all studies in this booklet comprise elements of design research, although there is a lot of variety, which includes combinations of design research with quasi-experimental design. All studies, however, do share the idea of trying to develop empirically grounded theories about both the process of learning and the means that are designed to support that learning. In that sense, it is classroom-based research. In most cases, the theories under consideration are local instruction theories. A notable exception is the study of Van den Boer (Chapter 4), who tries to identify the mechanisms that turn the dispositions of minority students into an educational disadvantage in mathematics education in comparison with native Dutch students. As such, Van den Boer's research is the most outspoken example of the focus on understanding and the corresponding conception of causality that underlies design research.

Here it may be helpful to use Maxwell's (2004) distinction between two complementary ways of identifying causal relations, a regularity conception of causality that is connected to observed regularities, and a process oriented conception of causal explanation, "that sees causality as fundamentally referring to the actual causal mechanisms and processes that are involved in particular events and situations" (Maxwell, 2004, p. 4). The latter, which refers to "the mechanisms through which and the conditions under which that causal relationship holds" (Shadish, Cook & Campbell, 2002, cited in Maxwell, 2004, p. 4), corresponds with the type of causal explanation that we look for in design research.

Similar causal explanations are sought in research focusing on specific aspects of the learning ecologies involved in design research. Examples of this can be found in the studies of Bakker (Chapter 6) and of Drijvers (Chapter 7), which are part of a larger project dealing with ‘Mathematics & ICT’. Apart from the shared interest in information technology, and the development of instruction theories, both studies also deal with symbolizing. Bakker studies the role of symbolizing in statistics education, in part by using the theoretical framework of Pierce. Drijvers uses the theoretical framework of instrumentation that is developed by a group of French researchers (Artigue, 2002) to investigate the constraints and affordances of computer algebra for the development of the concept of parameter. This connects these two studies to the work of Van Amerom (Chapter 5), who found that symbolizing and reasoning develop independently in early algebra, while algebraic reasoning appeared to be more accessible for middle school students.

Together, these studies display a rich variety of topics and approaches in design research on RME in and around the Freudenthal Institute. With these classroom-based research studies we believe we can substantiate our claim of doing research that pairs a quest for understanding with considerations of use, and we do hope these summaries encourage the readers to take note of the actual dissertations to evaluate this claim.

## References

- Artigue, M. (2002). Learning mathematics in a CAS environment: The genesis of a reflection about instrumentation and the dialectics between technical and conceptual work. *International Journal of Computers for Mathematical Learning*, 7, 245-274.
- Maxwell, J.A. (2004). Causal Explanation, Qualitative Research, and Scientific Inquiry Education. *Educational Researcher*, 33(2), 2-11.
- Stephan, M., J. Bowers, P. Cobb & K. Gravemeijer (Eds.) (2003). Supporting students' development of measuring conceptions: Analyzing students' learning in social context. *Journal for Research in Mathematics Education Monograph*, 12, Reston, VA: National Council of Teachers of Mathematics.
- Stokes, D.E. (1997). *Pasteur's quadrant: basic and technical innovation*. Washington DC: Brookings.
- Streefland, L. (1991). *Fractions in Realistic Mathematics Education. A Paradigm of Developmental Research*. Dordrecht, the Netherlands: Kluwer Academic Publishers.



---

## 2 Jumping ahead

*Julie Menne*

### 2.1 Introduction

This chapter reports on a research project, which was carried out in 1999 - 2002. This study discusses the development, the theoretical foundation and the evaluation of a productive training program for mental calculation with numbers up to 100; this program is intended especially for students with weak arithmetic skills in Grade 2.

In this training program, the *empty* number line takes a central role. Until 1950, the number line, when used in arithmetic with numbers under 100, was totally absent in textbooks and manuals published in the Netherlands. During the period up to 1970, there was increased didactical interest in the use of the *filled* number line, but the majority of conventional arithmetic textbooks paid no attention to this practice.

Under the influence of the Wiskobas project (1970-1980), it was the first time that lines with boxes and lines with marks began to play a role in arithmetic and mathematics textbooks with regard to comparing, ordering, positioning, and operating with numbers. However, in order to stimulate more shortcut calculation strategies, both the Wiskobas project and the textbooks were forced to switch to other models, such as the hundred square and the abacus.

Due to the ideas of Weill (1978), Whitney (1988), and Treffers (1989), the empty number line began to make progress as a didactic model during the 1990s in mathematics education in the Netherlands. Weill demonstrated how abbreviated calculations can be performed by placing numbers below and above an empty number line (Fig. 2.1).

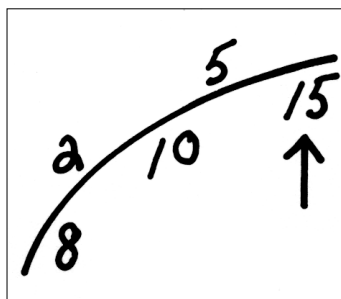

Figure 2.1

Whitney supplemented this concept with the idea that a vertical mark before a number on the empty number line represents the location of a toothpick on the string of beads (Fig. 2.2).

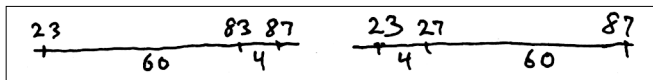

Figure 2.2

Treffers saw possibilities for learning to do abbreviated and flexible arithmetic with this model by assigning clear meaning to this mark while also using the ‘jump approach’ of Wiskobas (Fig. 2.3).

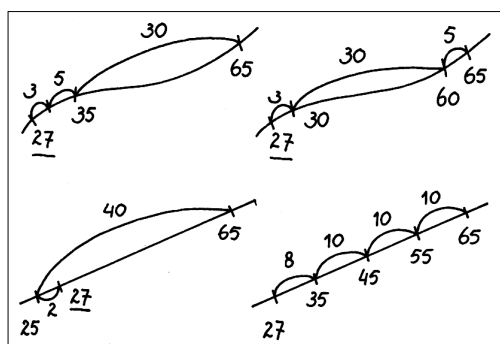

Figure 2.3

However, he observed that before students can operate on an empty number line with numbers, the following conditions must be met:

- the students must be able to count with tens and ones
- they must be able to locate numbers on a string of beads and on an empty number line
- they must be able to take a jump of ten from any number.

Studies conducted by Veltman (1993) and Klein (1998) then demonstrated that the empty number line is an useful scheme for adding and subtracting up to 100. For students with weak arithmetic skills, indications were also found that conditional activities, as previously observed by Treffers, must precede the use of the empty number line to solve problems.

The historical progression of the use of the empty number line, as discussed briefly above, brings us to the following set of research questions:

- 1 What is the effect of a program that can be developed for students with weak arithmetic skills which is based on basic counting arithmetic with ones and tens and which aims to have students move quickly and flexibly with jumps of varying length across the (empty) number line?
- 2 How can the relevant training program be didactically founded and embedded in the general framework of instruction theory of realistic mathematic education?

## 2.2 Framework

Of course the study needs a framework for instruction theory, which would provide a didactical foundation for the training program and would focus, via the general framework for instruction theory and the descriptive framework, on the outline of the local instruction theory for calculation up to 100. The following exercise serves as a guiding example:

*Tom is 63 years old. Tina is 48 years old.  
How many years older is Tom than Tina?*

In the general framework, the five principles of realistic mathematics education are: (a) productive contribution of the students, (b) meaningful activities and problems from the real world, (c) intermediary models, (d) interweaving with learning strand, and (e) interactive group instruction. Through the unique character of these principles – doing horizontal and vertical mathematization and vertical and horizontal interaction – this approach is compared with so-called mechanistic, structuralistic, and empiristic didactics. The structural approach lacks the horizontal component of mathematization, while the empirical one lacks the vertical component and the mechanistic both of them.

The descriptive framework and the local instruction theory are comprised of three micro- and three macro-didactical descriptive elements; these can be used to characterize the didactical directions referred to above.

The three micro-didactical components comprise:

- 1 the nature of the calculation in the basic operations and the degree of abbreviation that is used; in this case, the following classical distinction of strategies is generally applied: stringing (calculating on a line), splitting, and the flexible calculation method
- 2 the relative levels of formalization in the form of a three-part didactical system involving informal, context-linked calculation; semi-formal, model supported calculation; and formal disciplinary calculation
- 3 the applicability that is expressed in the contexts referred to by the numbers (e.g. money, distances and age), and the way the question is presented (e.g. by asking whether the difference in ages is always the same).

The three macro-didactical elements manifest themselves in the ‘length dimension’ of the relevant learning-teaching trajectory regarding for example subtraction with numbers up to 100. They show themselves in the ‘width dimension’ through their links with related learning-teaching trajectories, such as that of addition. Finally, they manifest themselves in the ‘depth dimension’ by indicating the relationship with the basic skills, such as calculation with numbers up to 20 and acquiring insight into the decimal structure of the number row up to 100.

In the local instruction theory for calculation with numbers up to 100, these micro- and macro-didactical descriptive elements are used to explore the global foundation of this theory. The proposition is:

*In order to be able to compare, order and locate numbers, and carry out the basic operations of addition, subtraction, multiplication, and division in the number domain up to 100, it is essential (and initially sufficient) that the students from grades 2 (and 3) are able to move quickly and flexibly across the (imaginary) empty number line with jumps or composite jumps of 10 and steps or composite steps of 1. Arithmetic instruction must initially focus primarily on acquiring these dynamic, basic skills.*

Regarding the nature of the calculation, the following areas are examined. How can rapid and flexible addition and subtraction skills be acquired most effectively and how can these skills be best applied in elementary context situations? Which aids (manipulatives, schematic representations, and models) are most suitable for bringing arithmetic skills up to the intended level of flexible, formal operation?

The stringing method (or calculating along a line), which develops from counting, is earmarked as the most fundamental arithmetic strategy. The splitting method is not given priority because this results in serious difficulties when applied to somewhat more complex subtraction problems. The varying calculation strategy permeates the entire learning strand in arithmetic up to 100; this method makes handy use of the arithmetical properties of the various operations.

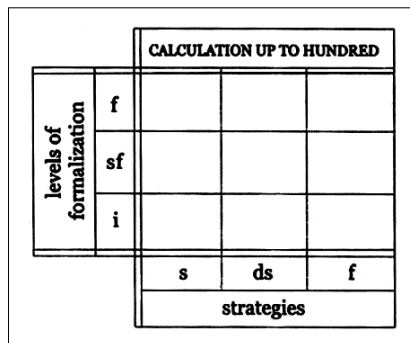

- f* = formal, disciplinary level  
*sf* = semi-formal, model supported level  
*i* = informal, context linked level  
*s* = stringing methods (calculating along a line)  
*ds* = decimal splitting methods  
*f* = flexible methods

Figure 2.4

Regarding the levels of formalization, it is proposed that the three calculation strategies can be combined with the three distinct levels of formalization. By using the nine categories of operation that are created in this way, the arithmetical operations of the children in the number area up to 100 can be described accurately (Fig. 2.4).

Since didactical primacy is assigned to the stringing method, it is obvious that one must first go through the levels of formalization with this method. During this process, the concrete basis of orientation must be implemented by using linear problem situations and models. These models have a dual function; they detach the operations from the concrete problem situation, and they create a bridge to formal operation. With splitting and the variation method, of course, one does not wait until the formal development of the stringing method has been completed. After all, helpful links can be established between stringing on the one hand and splitting and the flexible method on the other. These are links that can be clearly expressed in arrow diagrams.

Regarding the application problems, it is proposed that complex questions in realistic mathematics education, such as the Tom/Tina problem, should be preceded by a meaningful introduction. This provides such exercises with an actual meaning. Following this, however, disciplined practice should take place because the students must attain, or try to attain, the previously formulated objective in the number area up to 100.

As a criterion for a well-aligned learning strand, the cross section of the arithmetical operations of the student performances taken at a specific point in time should reflect a large part of the total length and structure of the relevant course of instruction – this is an indicator of the productive potential of the learning strand. The basic stringing method satisfies this criterion: the solution methods show a ‘well-aligned’ differentiation. This differentiation concerns both the degree of abbreviation and the formalization level at which the students are calculating.

In the length dimension of the learning-teaching trajectory, basic skills are acquired in the number area up to 20 that are crucially important for calculation with numbers up to 100. These skills are decomposition of numbers to 10 and the crossing-ten method. These skills can also be practiced with calculations up to 100.

The width dimension of the learning-teaching trajectory shows that the courses of instruction for subtraction, addition, and multiplication (as repeated addition) are strongly linked with each other. For addition or repeated addition as well, the decimal splitting approach must not be given priority before the children can add quickly and accurately using the stringing method. After all, there is a danger that the students will transpose this ‘easy’ splitting method for addition to subtraction, resulting in many of them becoming stranded.

In the depth dimension of the learning-teaching trajectory, there is a central didacti-

cal question of whether numbers should be ordered by primary counting and/or understood through decimal splitting. There are strong indications from neurological-psychological research that numbers are initially identified, compared, and ordered in accordance with their sequential location on the counting row, not through decimal splitting.

For the present study, the above considerations mean that we begin with the hypothesis that the students must first of all be able to move quickly and flexibly across the counting row. In order to achieve this aim, the following sub-skills must first be practiced and mastered:

- counting with tens and ones up to 100
- counting forward and backwards from any number up to 100 by tens and ones
- making jumps of 10 and 1 to any number
- being able to use knowledge of basic facts in the number area up to 10 (or 20) when making composite jumps along the empty number line.

### **2.3 Description of the productive training program**

How can we elaborate the previously outlined instruction theory for numbers up to 100 for practicing basic skills in this domain?

The specific characteristics of ‘productive practice’ in realistic arithmetic and mathematics education are discussed in contrast with the ‘reproductive practice’ that characterizes mechanistic arithmetic instruction. The contents of productive practice move between practising and exercising. As the learning process in school proceeds with the basic arithmetic skills (memorizing basic facts, automatize the processing of basic operations, and use them in a flexible way), the interactive training process in the classroom shifts increasingly from insightful practice to skillful mastery. Regarding practical application and solving problems, however, the accent remains on practicing.

The learning-teaching trajectory of the realistic training program is not, as with mechanistic arithmetic instruction, determined by the increasing complexity of the exercises, but by the progressive schematization and abbreviation of the solution strategies.

In order to assure that a training lesson proceeds as optimally as possible, not only in terms of content, but also of form, it must satisfy a number of form requirements. These requirements concern:

- oral training in a classroom setting where, among other things, the vertical and horizontal interaction is secured a good place.
- the technique used for training, for example, giving turns to the students
- the specific, leading role of the teacher, who provides a training period of approximately fifteen minutes at least three times per week.

The program is consists of two parts, 'numbers' and 'operations with numbers'. In the *numbers* section, the basic skills of counting, ordering and localizing, and jumping to numbers are discussed. Counting first requires children to count by ones from any randomly chosen number. The final objective is obtained when they are able to jump repeatedly over the number line with various starting numbers, sizes of jumps, and directions. Ordering and localizing are initially concerned with having students learn to determine the order and the position of numbers with respect to each other. After this, they practice the global positioning of numbers. A high level of localization of numbers is attained when the children can place a number between two other numbers with relative ease.

This skill can be practiced with a game such as 'guess my number'. When practicing jumping to numbers, it is the intention that the children achieve insight into the structure of numbers. In view of the decimal structure of the number row, jumping first takes place to numbers with jumps of 10 and hops of 1. The children do this initially on an imaginary number line and on the string of beads with a ten structure, and later on a drawn, empty number line. By expanding the hops of 1 to larger hops of 2 through 9, and the jumps of 10 to large jumps of 20, 30, 40 and so on, further abbreviations are possible. From jumping to numbers, the transition is made to operating with numbers on an empty number line.

The program section about *operations with numbers* is also broken down into a series of elementary skills: complementary addition to 10, partitioning, jumps of 10, and relating subtraction and addition. The complements to 10 are initially practiced on the upper row of the arithmetic rack. By means of the number images on the rack, the complements to 10 are memorized using the 'hearts in love'. In order to keep these hearts both interesting and functional for continuing arithmetic with numbers up to 100, variations and applications are provided. The partitioning section is introduced by means of doubling ( $3 + 3 = 6$ ); this is followed by reversing the problem by using 'fair sharing' (split 6 fairly into 3 and 3).

The process of doubling is pictured with paper 'twins', which, like the hearts, are derived from the arithmetic rack. With an eye towards calculation with numbers up to 100, most of the attention is placed on doubling the numbers 1 through 6, doubling 10 and decomposition the numbers 4,5,6, and optionally 7. The '10 jump' exercise has the objective of teaching the children to make a jump of 10 forward or backwards from a number up to 100, and conversely to be able to determine whether there is a difference of 10 between two numbers in this domain.

The 10 jump is initially presented implicitly by following the sound pattern in rows of numbers such as 22 - 32 - 42 - 52 - .... In order to provide children with the insightful basis for making the 10 jump, various stringing materials (string of beads) and decimal splitting materials (money) are used. In the stringing process, a so-called '10 catcher' serves as an aid. After some practice, the item "add 10, subtract 10" is included in the practice material and serves as a warm-up for problems such as 43 –

30 and  $23 + 19$  in both plain numerical and context forms. With the help of the ‘nearly disappearing’ problems – a subtraction problem where both components have nearly the same value – the relationship between subtraction and addition is made explicit in a step-by-step fashion. The final goal is for the children to be able to write down the addition and subtraction problems in mathematical notation and to perform the accompanying arithmetical operations without using manipulatives and schematic representations. The transition from informal, model-supported work to formal, skilled arithmetic progresses through a number of stages in the training program. The weakest arithmetic students carry out formal arithmetic not before group 5.

Finally, an impression of the style of training and the pedagogical atmosphere in which this training takes place is provided through the didactic form of the so-called *students’ own productions*. These consist, among other things, of thinking up as many exercises as possible using a specific number as an answer; these own productions are given a place in the training program throughout the year. Using this method, all the previously discussed didactical aspects can be addressed. The relationship with the general framework of instruction theory is expressed especially in this brief description of the learner’s own productions.

## 2.4 Development of the productive training program

The program developed continuously during the research process, as the initial program required modification. This section describes where and why the program was changed. In addition, the details of the guidance that was provided for the teachers who participated in the research experiment is reported, and their experiences and comments are discussed.

The research can be divided into three school years. The performances of the students were tested each year. The observations, the video recordings, the evaluations, and the interviews were especially important for directing the development of the training program. On the basis of this information, the program was repeatedly tried out and modified.

The first year can be described as an explorative year. Based on the previously discussed didactical principles, the research was initially directed at developing an interactive, classroom-based *training* program. This program focused on practicing basic skills, such as being able to quickly perform arithmetic with numbers up to 10, locating numbers, and counting with jumps of a composite unit. During this first year, I worked with small groups of children with poor arithmetic skills from Grade 2 in order to acquire experience with giving lessons that focus on practicing basic skills. I also practiced giving classroom-based, interactive lessons during which – while taking account of realistic arithmetic math principles – I attempted to deal as optimally as possible with the training material and the time allowed for training. The result of this exploration with regard to training was comprised of a number of

requirements which every training lesson should ideally satisfy, such as fixed sequences for questions and turns given to the children, a clear structure in the training material, differentiation for each training item, and repetition and expansion. Regarding the content of the program, I concluded that sufficient time for practicing counting must first be allotted before the children learn to make jumps and before they acquire insight into placing numbers in sequential order and into the decimal structure of numbers. At the end of the first explorative year, a card file with 100 training items was available.

The second, developmental year resulted in a number of supplements to productive training, such as having the children practice moving beads on an arithmetic rack and a string of beads according to a fixed pattern of sliding, checking and improving, and then returning the beads to their original position. At the beginning of the year, the emphasis was on the consistent implementation of game and behavioral rules that create the proper atmosphere for training. The training program was not rigidly limited and defined; if a student made a mistake, the teacher allowed the student to go back and use models. The children were encouraged to practice as much as possible outside the regular training periods.

With regard to learning the basic skills referred to above, two essential changes can be reported:

- the sequence in which attention was focused on the skills
- a further specification of what the skills included.

As a result, the objectives for calculation with numbers up to 10 during the first few months must be limited to:

- completing to 10
- doubling to 10.

Due to the well-considered limitation of calculation with numbers up to 10, more space was created for learning the counting row, locating numbers, and counting verbally with jumps. This is expressed in a training form where counting verbally with jumps is linked to physically jumping in the classroom. By counting while walking, and walking while counting, the students create an imaginary number line. This links up with the later use of jumps and operating with numbers on an empty number line. The empty number line therefore originates not primarily through the link with the string of beads, but especially from the children's own experiences with counting while jumping, and jumping while counting, on an imaginary line.

The final goal is, for the children to be able to count in a curtailed and skilled fashion using jumps of a composite unit. This skill consists of the following basic skills:

- learning the counting row
- jumping to numbers
- jumps of 10
- decompose numbers up to 10.

By combining these four skills with the previously discussed skills of locating numbers and restricted arithmetic with numbers up to 10, the separate training issues were developed which comprise the basic skills taught in the training program.

The other changes during this year concerned increasing attention for the students' own productions, for numbers up to 1000 and operations up to 1000, and the declining interest for assigning meaning to numbers. The card file has now been replaced with a manual that explains how the training must proceed based on the described objectives.

During the third, experimental year, eight Grade 2 classes at seven primary schools took part in the study. All the modifications that accompanied this broad contribution from the schools to the training program were in accordance with basic principles established during the developmental year. Most of the attention and concern this year focused on the implementation of the program. At the end of the experimental year, all the teachers were interviewed about their experiences in providing training, the guidance they received during this process, and the consequences for the use of the method.

All the teachers were very positive about the training program and reported that during a single year they had acquired insight into the basic skills that are essential for calculation with numbers up to 100. They also reported that they had acquired knowledge and expertise about how the skills can be developed, consolidated, and implemented for solving arithmetic problems as efficiently as possible. By having an overview of the learning-teaching trajectory, in combination with implementing interactive classroom-based training lessons, the teacher knows exactly where all students are located in the 'arithmetic plane'. This information can be used to decide on the sequence of lesson material, and the teacher can fall back on this information. The teachers believe that the supervision during the implementation of the training program should be comprised of plenary meetings, a manual, evaluations of observed practice lessons, and effective sample lessons.

Because the teachers acquired such detailed knowledge about the learning process of the students, they were able to 'rise above' the textbook. They were more confident about making choices regarding subject matter and the accompanying materials and models. They took more and more personal responsibility for the success of their lessons.

As a whole, the qualitative data resulted in a number of points of attention for the teacher's study program, supplementary training, and supervision, such as:

- teachers do not obtain information about training from textbooks
- working with textbooks does not lead to a practical theory for calculation with numbers up to 100
- when the teachers have internalized an overview of the learning-teaching trajectory, they feel more proficient and are stimulated to act more professionally.

For an implementation of the training program, this means that the practical implementation of the intended training cannot just take place on paper, but must also be part of a guided professionalization process. Stated another way, a method by itself is not enough; training lessons transcend the method.

The students who participated in the experimental year were tracked during Grade 2 by giving them *Cito* arithmetic tests and *MORE* arithmetic tests. *Cito* tests are standardized tests used in the Netherlands. The average results from these tests are representative of the performances of virtually all students in the Netherlands. *MORE* tests are derived from the Arithmetic-Mathematics Research Method and are used to measure the effect of realistic arithmetic-mathematics textbooks on the performances of the students. The *MORE* students do not represent the total population of students in the Netherlands. The *Cito* tests are therefore earmarked as being the most important because the scores can be compared with standardized data at the national level. The comparison with the data from the *MORE* results is interesting primarily in a relative sense.

## 2.5 Results

In this section the scores on the tests are presented and explained. The student group consisted of students from the experimental group (eight classes) and those from the control group (five classes).

Concerning the *Cito* results, the results are reported of the experimental group, the control group, the individual shifts in levels, the performances of native Dutch students and students from other cultural backgrounds, and the progress of the individual classes. In addition, the scores of these groups and the subgroup of students from other cultural backgrounds are analyzed at the item level.

Half of the students in the experimental group achieved one or more levels higher than their initial *Cito* testresults. One-third reached the same level as a year earlier and one-sixth scored lower than the initial test. This progression applies particularly to the weaker arithmetic students who mainly belong to the group of students from non-Dutch cultural backgrounds.

According to the comparative *Cito* data, 60 students from the experimental group performed at the 25<sup>th</sup> percentile (levels *E*, *D*) before the start of the program (therefore among the weakest students in the Netherlands). After a year of working with the training program, there were only 34 students still performing at this level. The students from the experimental group that scored in the next 25% also made progress. The scores of students from this group who performed above percentile .50 at the start of the program declined slightly.

Sixty percent of the students from the experimental group belong to the group of students with non-Dutch cultural backgrounds. More than half of this group initially

scored at the 25<sup>th</sup> percentile (among the weakest students in the Netherlands). Following the completion of the experiment, this number was cut almost in half. The number of students from non-Dutch cultural backgrounds that performed above percentile .50 doubled at the same time. If one looks at the eight classes in the experimental group, it is striking that the five classes with an average score below percentile .50 are the ones that made the most progress on the tests.

On the final test, context problems were used such as '45 + 27' and '43 – 18'. For this set of problems, the students from the experimental group as a whole scored higher than the national average, but even more striking, so did the students from non-Dutch cultural backgrounds.

The progress of the experimental group can be accentuated even further when they are compared with the results of the control group. The control group consisted of 52 students including 40 from non-Dutch cultural backgrounds, all of whom took the *Cito* tests. In the period of one year the number of students in the control group that were classified in the lowest 25% (levels *E*, *D*) increased slightly. The number in the top 50% also declined slightly. If the decline in performance of the top 50% of the students from the experimental group and the control group are considered separately, the students of the control group performed relatively more often at a lower level after one year. Moreover, of the five control groups, one attained the same average at the end of Grade 2 than at the end of Grade 1 and only one attained an average higher score over the same period. With the experimental group, however, this latter was the case with six of the eight classes.

On the core items '45 + 27' and '43 – 18', the experimental group scored 79% and 66% correct respectively. This was higher than the control group, whose students answered these questions correctly 75% and 52% of the time. It was also higher than the *Cito*-standardized group, students of which answered these questions correctly 66% and 53%, respectively.

	distribution of percentages at Cito test levels end of grade 1					correct scores end of grade 2	
	E	D	C	B	A	'45+27'	'43-18'
Cito standard group	10	15	25	25	25	66	53
exp. group	18	22	22	20	18	79	66
non-Dutch. exp. group	26	28	25	12	9	78	59
control group	13	13	34	20	20	75	52
non-Dutch control group	18	18	40	12	12	68	45

Table 2.1

The non-Dutch students in the experimental group also scored better in the addition and subtraction problems than the students in the control group or the standard group. The starting situation for the experimental group at the beginning of the teaching experiment was clearly less advantageous than for the control and standard groups, which makes the achievements of the students in the experimental group on these core items all the more remarkable (Table 2.1).

The results of the *MORE* tests also support the findings of the *Cito* tests for the experimental group and the control group. The average scores of the experimental group, the control group, and the entire *MORE* group were compared on the test as a whole and at the item level. However, no comparative data for students from non-Dutch cultural backgrounds are available for the *MORE* test.

The experimental group made more progress than the *MORE* group and the control group. This applied equally to the students from non-Dutch cultural backgrounds in the experimental group when they were compared with similar students from the control group. In absolute terms, the control group – therefore including the subgroup of students from non-Dutch cultural backgrounds – remained somewhat behind the *MORE* group. Consequently, this applies even more if the performances of the control group are compared with those of the experimental group.

At the item level, the performances on the context problems ‘ $12 + 28 + 31 + 19$ ’ and ‘ $25 + 33 + 17 + 15$ ’ and the plain numerical subtraction problems ‘ $94 - 29$ ’ and ‘ $33 - 25$ ’ were examined. The students from the experimental group performed better on these problems than the students from the control group and the *MORE* group as a whole. The same applies when the students from non-Dutch cultural backgrounds in the experimental group are compared with those from the control group.

Based on the test results, it can be concluded that the training program developed in this study has created a solid foundation for calculation with numbers up to 100. This is especially true for the students from non-Dutch cultural backgrounds who performed relatively well on difficult problems such as ‘ $43 - 18$ ’ and ‘ $33 - 25$ ’. With the development of the productive training program, its professional-didactical foundation, its indication of the importance of regular practice, the observations of the teachers about the program, and the results attained by the students, it appears that an important objective in realistic mathematics-arithmetic education for students with weak arithmetic skills has been realized.

Would the results just be as positive if a training program had been developed in which splitting instead of stringing was the main method in a comparable didactical developmental study? This question is answered by successively considering the following core issues:

- the transparency of the model of the empty number line
- the didactical primacy of the accompanying varied stringing methods, especially in relation to splitting

- the relationship of stringing to varied arithmetic, in particular the question whether varied, flexible calculation strategies can be given sufficient attention in the stringing approach.

We may not assume that children see and understand the empty number line in the same way as more skilled arithmetic students do. It can happen that informal arithmetic operations on an empty number line have no connection to the corresponding formal arithmetical operations for which this model should of course be offering the concrete support. During the training program this problem did not crop up however. The arithmetic operations corresponded closely to the counting solution strategies the children themselves proposed. Based on this informal beginning the empty number line can function as an arithmetic stripe. The leading didactical function allotted to the teachers plays an important role in this situation; they must not leave any misunderstandings uncleared, they must explain, clarify the problem situation, and rather than aiming at the students' horizontal interaction, they should put forward relationships and strategies rich in perspectives. If the students' arithmetic operations correspond to the counting and drawing operations clearly and in a way which cannot be misunderstood and if they can 'read' the scheme given below and, conversely, can visualize the arithmetic sentence when it is presented in words or mathematical notation, then the empty number line is a transparent model for them (Fig. 2.5).

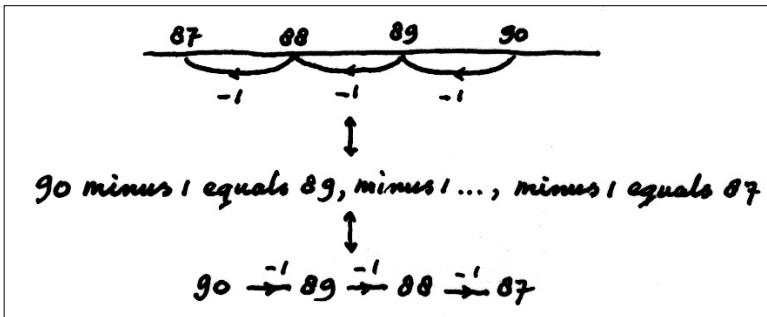

Figure 2.5

For the splitting method, the result of the mathematical-didactical analysis of the pure splitting subtraction can only mean that this arithmetic strategy offers little perspective in the initial arithmetic teaching trajectory, this approach does not connect with the children's natural input. Varied arithmetic can, however, become well developed through the stringing method. Varied counting and stringing and the dynamic orientation to numbers not only leads to the students building up a network of number relations, but also to their understanding of the basic characteristics of operations and the relationships between operations. The splitting method, on the other

hand, is performed through a fixed procedure, a prescribed arithmetic recipe.

The conclusion is that the positive results of the teaching experiment with the productive training program must have been achieved through the didactical concept of the varied stringing approach. Starting from the children's productive input, there is no initial introduction which leads to the pure splitting method. The didactical principles of this productivistic approach are upheld in accordance with the empirical and rational-didactical analysis of the teaching experiment.

## References

- Klein, A.S. (1998). *Flexibilization of mental arithmetic strategies on a different knowledge base: The Empty Number Line in a Realistic versus Gradual Program Design* (diss.). Utrecht: CD-β Press / Freudenthal Instituut.
- Treffers, A. (1989). *Het voorkomen van ongecijferdheid op de basisschool*. Utrecht: OW & OC (oratie).
- Veltman, A. (1993). *Van het begin en van het eind: Ontwikkelingsonderzoek naar het rekenen tot 100 op de (lege) getallenlijn* (doctoraalscriptie). Utrecht: Faculteit Sociale Wetenschappen.
- Weill, B.F. (1978). Mrs Weill's Hill: A successful Substration Method for Use with the Learning-Disabled Child. *Arithmetic Teacher*, 26, 2, p.34-35.
- Whitney, H. (1988). *Mathematical Reasoning, Early Grades: growth through involvement, curriculum outline* (ongepubliceerd manuscript). Princeton: Institute for Advanced Study.



---

## 3 Teaching formal mathematics in primary education

Ronald Keijzer

### 3.1 Mathematising in Realistic Mathematics Education

This chapter reports on the research project ‘Teaching formal mathematics in primary education’, which was carried out in 1992 - 2003.

A demand of our present day technological society is that human beings need to learn to deal with abstract concepts and formal relations. From these societal needs, educational psychology has strongly aimed at cognitive processes and problem solving strategies (Greeno, Collins and Resnick, 1996). In order to enable students to participate as competent members of their community, it is important to guide children in the required strategies of symbolisation, modelling, abstraction, formalisation and generalisation; to cope with key elements in mathematising one’s world (Sierpinska & Lerman, 1996; Streefland, 1997; Schoenfeld, 1994).

More than thirty years ago constructing mathematics as human (mental) activity formed the basis of Dutch Realistic Mathematics Education (RME) (Freudenthal, 1973; Gravemeijer & Terwel, 2000) and mathematising was established as a major learners’ activity (Gravemeijer, 1994; De Corte, Greer & Verschaffel, 1996; Gravemeijer, 2001). A phenomenological analysis of mathematical structures and its learning lead to programmes based on the principles of RME (cf. Freudenthal, 1983). RME teaching and learning starts with recognisable contexts. These meaningful situations, in time, are mathematised to form more formal relations and abstract structures (Van den Heuvel-Panhuizen, 1996). Treffers (1987), here, made a distinction between horizontal and vertical mathematisation. The former involves converting a contextual problem into a mathematical problem, the latter involves taking mathematical matter onto a higher plane. Vertical mathematisation can be induced by setting problems which admit solutions on different mathematical levels (Freudenthal, 1991; Gravemeijer & Terwel, 2000). Moreover, embedding vertical mathematisation in RME makes that RME is not limited to applying mathematics in recognisable contexts, but has the potential to develop formal mathematics in students.

This study focuses on learning mathematics in an RME-context. Moreover, it considers the developmental process leading to an RME fraction programme. This study therefore is about constructing and teaching mathematics. With this we follow in particular Freudenthal (1991), and take a phenomenological point of view, where mathematical strategy acquisition is considered as a process of ‘*guided reinvention*’. Freudenthal underlined the necessity of student guidance while learning mathematics; he pleaded for guided *reconstruction*. Moreover, he recognised that mankind developed mathematics to solve all sorts of practical problems and that students should be guided to re-experience this lengthy process in only a few years, similar

to the way in which mathematics evolved to the science of structures and became formal mathematics, which in some cases lost many of the obvious links to daily life (Struik, 1987; De Corte, Greer & Verschaffel, 1996).

### **3.2 Fraction learning**

Streefland (1991) constructed a fraction programme in a RME setting. By using situations of fair sharing he stimulated students to develop a fraction language. Streefland argued how the sharing context lead to the fraction notation and provided a means to model fractions both as circle parts and as numbers in a ratio table. He elaborated on this last fraction representation to constitute equivalent fractions and formal fraction subtraction and addition. The experimental programme described here is also constructed in an RME setting. This programme, in a similar manner, evokes fraction language, but uses measuring situations instead of situations of fair sharing. These measuring situations next prepare for positioning fractions on a number line, where equivalent fractions come forward as fractions in the same position, thus forming a base for fraction operations.

Fraction learning in an RME context, thus considered, is a typical example of a mathematising process, as it can be seen as a process of modelling, symbolising, generalisation, abstraction and formalisation (Treffers, 1987; Freudenthal, 1991; Nelissen, 1998; Gravemeijer & Terwel, 2000). Moreover, fraction learning aims at vertical mathematisation, as one rarely experiences fractions in daily life; the fraction concept is about abstract and formal relations. However, this limited bound to reality probably makes fractions the most difficult subject in primary school (Behr, Harel, Post & Lesh, 1992; Hasemann, 1981). This furthermore makes that some question the need for (formal) fractions in primary school (cf. Goddijn, 1992).

### **3.3 Research questions and hypothesis**

This study researches the feasibility and effectiveness of a newly developed fraction programme in primary school, as compared to a widely used programme in a somewhat traditional educational setting. The newly developed programme is reflected upon, to further improve it to the needs of present day education (Gravemeijer, 1994; cf. Gravemeijer, 2001). Moreover, the study is conducted to provide arguments on to what extent students can and should participate in a fraction programme aimed at formal fraction acquisition.

From this point of view we formulated the following general research questions:

- 1 How are mathematisation processes facilitated for 10-11 year old children, especially in the case of fraction acquisition?
- 2 What main obstacles can be distinguished concerning the processes of vertical mathematisation for 10-11 year olds, especially in the case of fraction acquisition?

We specified these questions in the following specific research question:

*How do student learning processes develop in an experimental curriculum in which the number line is used as a model for fractions, and meanings are established by negotiation, and what are the learning outcomes of the developed programme as compared to a control group, which learns fractions in a more traditional programme, where the circle is the central model and where learning, to a large extent, is a solitary activity?*

In elaborating the outcomes of the programme comparison, we will focus especially on possible differential effects (cf. Hoek, Terwel & Van den Eeden, 1997; Hoek, 1998; Hoek, Van den Eeden & Terwel, 1999).

From this perspective, our research questions lead us to the study's hypotheses:

*A majority of 10-11 year old students can acquire abstract and formal mathematical concepts and strategies, when these concepts and strategies are learned in an educational setting, where meanings are negotiated in meaningful and recognisable situations (Greeno, 1991) and where mathematical activities on different levels are closely connected (Van Hiele, 1986; Pirie & Kieren, 1989; Pirie & Kieren, 1994; Gravemeijer, 1994).*

*We specified that students who learned fractions in a programme in which the number line is used as a model for fractions, and meanings are established by negotiation, will outperform students who learned fractions in a more traditional programme, where the circle is the central model and where learning is to a large extent a solitary activity.*

### 3.4 Methods

The research described here was conducted at a school in a small town north of Amsterdam. The students visiting the school in general have a middle class background. From two parallel grade 6 groups (9 to 10 years) we selected an experimental group which followed a newly developed programme, and a control group which followed the more traditional fraction programme of the school. We thoroughly observed and analysed the fraction learning processes of students in both the experimental and the control group during a whole school year. We ordered our analyses to further identify and clarify key elements in fraction learning and to generalise findings to learning processes that are involved in formal mathematics acquisition. The conceptual model of the study schematises key elements in the research described here (Fig. 3.1). Teaching in the experimental group initially focuses on fraction language acquisition through student exploration of measuring situations.

Here, the bar and the number line are subsequently introduced as (mental) models for fractions. In the control group the subject is introduced by fair sharing and the circle-model. In the experimental group students are invited to discuss, in the control group students mostly work individually.

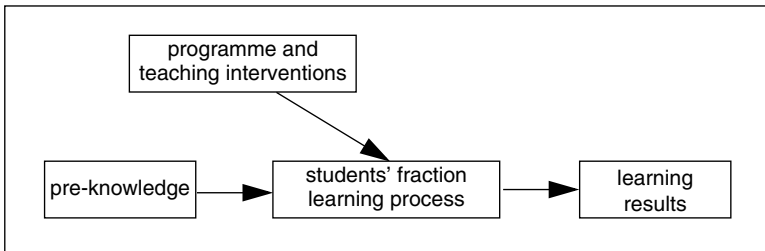

Figure 3.1 Conceptual model guiding the study

In line with what Anderson, Greeno, Reder & Simon (2000) suggest on attuning appropriate research approaches to relevant research issues, we used several methodological approaches to analyse the aforementioned fraction programmes and their students outcomes with various coherent instruments.

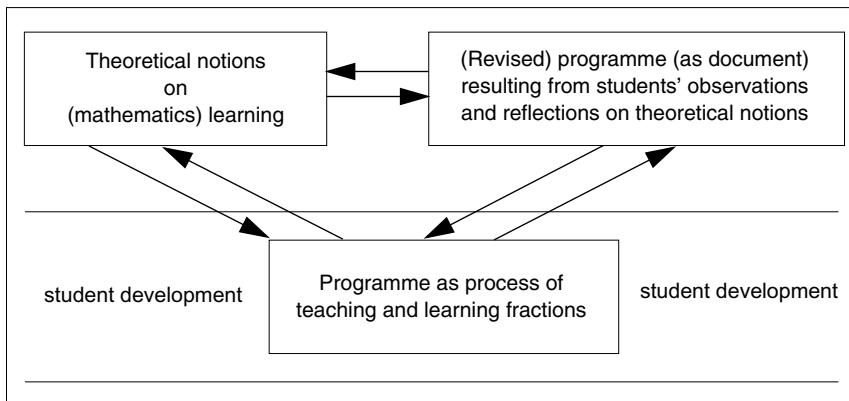

Figure 3.2 Framework for developing mathematics education

This is based on considering developmental research to be an overarching research design, that is to say, the developmental research design could be considered to contain any concise form of active search or reflection leading to arguments to (a continuous) improvement of mathematics programmes (cf. Gravemeijer, 1994; Terwel, 1984) and this study is conducted to provide those arguments. We visualise this overarching character of developmental research in figure 3.2, where we relate con-

siderations in teaching and learning fractions. In the conceptual framework of the study (figure 3.1), which could be considered as derivation from the developmental research scheme, we schematise key-elements in the research: the two programmes, teaching experiments, student development and pre- and post-tests. Research interventions are embedded in a quasi-experimental research design (Cook & Campbell, 1979), more precisely a non-equivalent pre-test post-test control group design, where students in the experimental group follow the experimental curriculum and students in the control group follow the control programme.

In Table 3.1 we provide a specification of the research design. In this design  $O_1$ ,  $O_2$  and  $O_3$  are standardised tests to ascertain students' general mathematical strategies at the start, halfway through and at the end of the research year. Three standardised interviews,  $I_1$ ,  $I_2$  and  $I_3$  were held to determine students' fraction knowledge at the start, halfway through and at the end of the research year, and thorough observations during fraction instruction in both experimental group ( $Xe_1, Xe_2, Xe_3, Xe_4$ ) and control group ( $Xc_1, Xc_2, Xc_3, Xc_4$ ) were conducted to provide for additional information on student development.

$O_1$	$Xe_1$	$I_1$	$Xe_2$	$O_2$	$Xe_3$	$I_2$	$Xe_4$	$O_3$	$I_3$
$O_1$	$Xc_1$	$I_1$	$Xc_2$	$O_2$	$Xc_3$	$I_2$	$Xc_4$	$O_3$	$I_3$

Table 3.1 Specification of the research design

Student observations provided us with a means to perform two case studies. In each of these case studies we describe the development in fraction learning of one of the students in the developed programme. To do so, we analysed all lessons in the experimental curriculum, to select the moments that clearly exhibit the students' development. Next the theory of RME helped us to interpret and – in some sense – generalise the findings (cf. Yin, 1984).

### 3.5 Research setting

Twenty students from two grade 6 groups (aged 10/11) participated as subjects in this study. We matched the twenty students in ten pairs, with one student in the experimental group and one in the control group. In this way ten students followed the experimental curriculum, in which the number line is used as a model for fractions and where meanings are established by negotiation.

Their counterparts in the control group followed the more traditional fraction programme of the school, where the circle is the central model and where learning, to a large extent, is a solitary activity. The researcher was the teacher in the experimental group during the lessons in fractions. The experimental group's regular teacher took care of all other mathematics topics in this group. The control curriculum was taught

by the regular teacher of the group, as were other mathematics topics in this group. The teaching styles of the two teachers were highly comparable and apart from the fraction programmes, all mathematics topics were dealt with in a similar manner. At three points we measured students' proficiency in general mathematical strategies. Additionally, we established students' fraction strategies from three standardised interviews.

### 3.6 Results

The study presented here researches the feasibility and effectiveness of a newly developed fraction programme in primary school, as compared to a widely used programme. In this programme fraction learning is just an example of a learning process in mathematising, i.e. 'making it more mathematical' (Freudenthal, 1968).

We analysed the effects of the experimental programme by testing students several times on general mathematical strategies. On only one occasion did we find significant differences when comparing the student results in a paired t-test. Normal performing students who followed the experimental programme significantly outperformed their matched counterparts in the control group on the post-tests 'numbers and operations' and 'measurement and geometry'. This finding indicates the differential effects.

We did not find significant results when comparing general mathematical strategies for all the paired students in paired t-tests and in regression analyses. However, clear interaction effects between the condition and post-tests were found, meaning that we established differential effects of the experimental programme as compared to the control condition. Namely, the experimental programme benefits the better performing students more than the control programme, a 'Matthew-effect' (Kerckhoff & Glennie, 1999). We were able to distinguish intervals of significance; intervals of pre-test scores where one condition does significantly better than the other. We found that for the post-test 'numbers and operations' low achievers benefited more from the control condition than from the experimental condition. For the post-test 'measuring and geometry' we also did find significant differential effects. Here we were able to distinguish two intervals of significance. These intervals in pre-test scores indicated that the highest achieving students benefited more from the experimental condition as compared to the control condition, whereas the lowest achieving students benefited more from the control condition as compared to the experimental condition.

We analysed the effects of the programme on students' fraction strategies. We established these fraction strategies in three interviews. We constructed the interviews so that students who were unable to clarify the problem situation themselves received

standardised help. In a paired t-test we found that students in the experimental group did significantly better in these fraction interviews than their peers in the control group ( $p \leq 0.05$ ). However, a regression analysis, that corrected the scores for small initial differences, revealed that two of the three fraction interviews turned out to be clear, but non-significant, trends. Moreover, for the fraction interviews we established no interaction between the condition and pre-test scores. We therefore concluded that high and low achieving students do not benefit differently from the experimental condition as compared to the control condition.

We did not find significant results in the interviews in all cases when we limited ourselves to the condition that no help was offered. We reckon that the small number of subjects plays a role here. However, students in the experimental condition possibly did better when standardised help was offered, because this enabled students to use strategies that were accentuated in the experimental programme, like making estimations, checking answers by making a sketch, et cetera. Students with possibilities to learn and use mathematical language more easily, are the high performers in mathematics, and they therefore gain in a situation where common understandings are discussed.

Moreover, we argued that low achievers are possibly hindered by the formal and abstract nature of the fractions involved or by the difference in teaching style between researcher-teacher in fraction lessons and the students' regular teacher. Furthermore, a qualitative analysis of the students' work revealed that students in the experimental condition in their answers more frequent reflected number sense than students in the control group. We interpreted that these results indicated that the experimental programme led to better results.

### 3.7 Fraction learning processes

We presented this study as one where quantitative and qualitative analyses are used to provide in-depth insight in students' learning processes. We expressed this choice in the study's research questions. This study is performed to uncover *how* mathematization processes are facilitated for 10-11 year old children, especially in the case of fraction acquisition. Moreover, this study looks for obstacles that can be distinguished regarding the processes of vertical mathematization for 10-11 year olds. Therefore qualitative analyses are needed to answering our research questions.

We analysed learning processes in the experimental fraction curriculum as compared to the effects of the programme in a control group. An analysis of the data provided indications for the following:

- Students in the experimental condition show more proficiency in fractions than students in the control condition.
- Students who perform average or above average in general mathematical skills can learn formal fractions in a meaningful manner and within reasonable time.

- Low achievers in mathematics experience considerable difficulties in learning formal fractions.

These findings partly confirm the study's specific hypothesis. We found strong indications that students in the experimental curriculum do outperform control students in the more traditional programme in fraction proficiency; however, if we focus on general proficiency in mathematics, only above average performers in the experimental group benefit more from the experimental condition than from the control condition. These results, moreover, provide strong indications for this study's general hypothesis that states that a majority of 10-11 year old students can acquire abstract and formal mathematical concepts and strategies, when these concepts and strategies are learned in an educational setting where meanings are negotiated in meaningful and recognisable situations and where mathematical activities on different levels are closely connected, as the experimental condition can be considered to be such a setting.

### **3.8 Conclusion**

The main conclusion based on the quantitative part of this study, using the outcomes of the regression analysis while controlling for small initial differences and searching for interaction effects, can thus be stated as follows. Although clear trends were found in the expected direction, strictly speaking we cannot substantiate a significant general effect of the programme on the learning gains of the students. This conclusion holds true for both the effects on general mathematical strategies as on the outcomes of fraction learning. Therefore, in general the hypothesis has to be rejected. However, thorough qualitative analyses of students' learning strategies indicated that the experimental programme offers many students chances to learn fractions in a meaningful way. Students that followed the control programme showed less flexibility in operating and manipulating with fractions than their matched peers in the experimental condition.

Moreover, although no general effects for all students were found, the study showed significant differential effects. As far as the effects on general mathematics strategies is concerned, high achieving students clearly benefitted from the programme while low achieving students showed significantly less gains as compared to their counterparts in the control programme. Thus there is an effect of the programme which is not only statistical significant but also relevant for both educational theory and practice.

## References

- Anderson, J.R., J.G. Greeno, L.M. Reder & H.A. Simon (2000). Perspectives on Learning, Thinking, and Activity. *Educational Researcher*, 29(4), 11–13
- Behr, M.J., G. Harel, Th. Post & R. Lesh (1992). Rational number, ratio, and proportion. In: Douglas A. Grouws (ed.) *Handbook of research on mathematics teaching and learning*. (296-332). New York: Macmillan Publishing Company
- Cook, Th.D. & D.T. Campbell (1979). *Quasi-Experimentation. Design & Analysis Issues for Field Settings*. Chicago: Rand McNally College Publishing Company.
- De Corte, E., B. Greer & L. Verschaffel (1996). Mathematics Teaching and Learning. In: David C. Berliner & Robert C. Calfee (eds.). *Handbook of Educational Psychology*. New York: Simon & Schuster Macmillan, 491-549.
- Freudenthal, H. (1968) Why to teach mathematics as to be useful? *Educational Studies in Mathematics*, 1(1), 3-8.
- Freudenthal, H. (1973). *Mathematics as an Educational Task*. Dordrecht: Riedel.
- Freudenthal, H. (1983). *Didactical phenomenology of mathematical structures*. Dordrecht: Riedel-Kluwer.
- Freudenthal, H. (1991). *Revisiting Mathematics Education, China lectures*. Dordrecht: Kluwer Academic Publishers.
- Goddijn, A.J. (1992). De oudste en de nieuwste breuken [The oldest and the newest fractions]. *Tijdschrift voor nascholende en onderzoek van het reken-wiskundeonderwijs*, 11(2), 18-31.
- Gravemeijer, K.P.E. (1994). *Developing realistic mathematics education* (dissertation). Utrecht: CD-B Press.
- Gravemeijer, K.P.E. & J. Terwel (2000). Hans Freudenthal: a mathematician on didactics and curriculum theory. *Journal of Curriculum Studies*, 32(6), 777-796.
- Gravemeijer, K.P.E. (2001). *Reken-wiskundeonderwijs voor de 21<sup>e</sup> eeuw* [Mathematics education for the 21<sup>st</sup> century]. Utrecht: Utrecht University.
- Greeno, J.G. (1991). Number sense as situated knowing in a conceptual domain. *Journal for Research in Mathematics Education*, 22(3), 170-218.
- Greeno, J.G., A.M. Collins & L. Resnick (1996). Cognition and Learning. In: David C. Berliner & Robert C. Calfee (eds.). *Handbook of Educational Psychology*. New York: Simon & Schuster Macmillan, 15-46.
- Hasemann, K. (1981). On difficulties with fractions. *Educational Studies in Mathematics*, 12, 71-87.
- Heuvel-Panhuizen, M. van den (1996). *Assessment and realistic mathematics education* (dissertation). Utrecht: CD-B Press.
- Hiele, P.M. van (1986). *Structure and Insight. A theory of Mathematics Education*. Orlando: Academic Press, Inc.
- Hoek, D., J. Terwel & P. van den Eeden (1997). Effects of Training in the Use of Social and cognitive Strategies: An Intervention Study in Secondary Mathematics in Co-Operative Groups. *Educational Research and Evaluation*, 3(4), 364-389.
- Hoek, D.J. (1998). *Social and cognitive strategies in co-operative groups. Effects of strategy instruction in secondary mathematics* (dissertation). Amsterdam: University of Amsterdam.
- Hoek D., P. van den Eeden, J. Terwel (1999). The effects of integrated social and cognitive strategy instruction on the mathematics achievement in secondary education. *Learning & Instruction*, 9, 427–448.
- Kerckhoff, A.C. and E. Glennie (1999). The Matthew effect in American education. In: Aaron M. Pallas (ed.). *Research in sociology of education and socialization (Vol. 12)*. Stamford, Connecticut: Jai Press Inc, 35-66.
- Nelissen, J.M.C. (1998). Representaties in het reken-wiskundeonderwijs [Representations in mathematics education]. *Pedagogische Studiën*, 75, 169-183.
- Pirie, S.E.B. & T.E. Kieren (1989). A Recursive Theory of Mathematical Understanding. *For*

- the Learning of Mathematics*, 9(3), 7-11.
- Pirie, S.E.B. & T.E. Kieren (1994). Beyond Metaphor: Formalising in Mathematical Understanding within Constructivist Environments. *For the Learning of Mathematics*, 14(1), 39-43.
- Schoenfeld, A.H. (1994). Reflections on Doing and Teaching Mathematics. In: Alan H. Schoenfeld (ed.). *Mathematical thinking and problem solving*. Hillsdale, NJ: Lawrence Erlbaum Associates, Publishers, 53-70.
- Sierpinska, A. & S. Lerman (1996). Epistemologies of Mathematics and of Mathematics Education. In: Alan J. Bishop, Ken Clements, Christine Keitel, Jeremy Kilpatrick & Colette Laborde (eds.). *International Handbook of Mathematics Education (part 2)*. Dordrecht, Boston, London: Kluwer Academic Publishers, 826-876.
- Streefland, L. (1991). *Fractions in Realistic Mathematics Education, a Paradigm of Developmental Research*. Dordrecht: Kluwer Academic Publishers.
- Streefland, L. (1997). Een geval van reflectief denken in ontwikkeling met verhoudingen als paradigma (slot) [A case of developing reflective thinking with ratio as paradigm]. *Tijdschrift voor nascholing en onderzoek van het reken-wiskundeonderwijs*, 15(3), 22-31.
- Struik, D.J. (1987). *A Concise History of Mathematics (fourth revised edition)*. New York: Dover Publications, Inc.
- Terwel, J. (1984). *Onderwijs maken* [Making education] (dissertation). Harlingen: Flevodruk.
- Treffers, A. (1987). *Three dimensions. A model of Goal and Theory Description in Mathematics Instruction – the Wiskobas Project*. Dordrecht: Reidel Publishing Company.
- Yin, R.K. (1984). *Case study research. Designs and Methods*. Beverly Hills, CA: SAGE Publications.

---

## 4 If you know what I mean

*Corine van den Boer*

### 4.1 Motivation for the research

This chapter reports on the research project ‘Ethnic minorities in the Dutch educational system’<sup>1</sup>, which was carried out in 1995 - 2003. As in many other countries, ethnic minority groups in the Dutch education system find themselves in a disadvantaged position. Particularly in mathematics, student results from the ethnic minority groups remain behind those from non minority groups. At the beginning of primary education, the educational achievements of minority students are, on average, lower than those of their Dutch contemporaries. Although it turns out that this disadvantage decreases during the students’ school career, but it does not disappear completely. The educational disadvantage is most severe for Moroccan, Turkish and Surinam students (see among others De Wit a.o., 1996).

Research into the school career of a large group of ovb-target students<sup>2</sup> over three years of secondary education (De Wit a.o., 1993; Suhre a.o., 1996), among other things, brings to light that minority students do not uptake as many science-based subjects for their examination as Dutch students with the same grades. In (individualised) pre-vocational education and junior general secondary education, minority students do take less science-based subjects than Dutch students, but take these subjects at a lower level<sup>3</sup>, get more ‘unsatisfactory marks’ and more often fail their exams.

Like many other organizations, the Centre for Science and Mathematics Education (CD $\beta$ ) is worried about these developments. After all, successful participation in secondary mathematics and science education is an important factor for students’ future employment choices. This means that when minority students have problems in relation to exact subjects, this will limit choices for their future.

In 1994, CD $\beta$  submitted a project proposal to the Utrecht University ‘Stimuleringsfonds voor maatschappelijke aandachtsgebieden.’ The purpose of this proposal was to inventory the situation of minority students in exact subjects and to formulate in-

1. Granted by the Stimuleringsfonds Maatschappelijke Aandachtsgebieden of Utrecht University.
2. OVB stands for educational priority policy. OVB is aimed at fighting educational disadvantages of minority students and Dutch working class students. The most important target groups are: Dutch working class children (in other words the 1.25-students) and minority working class children (in other words the 1.90-students)
3. Students in (individualised) pre-vocational education and junior general secondary education - (i)vb and mavo in Dutch - can take general subjects at different exam levels. Mavo students can take exams at C - or D-level, with C being the lowest level. (I)vb students can take the exams at A- or B-level as well. C- and D-level are national exams, A and B are set by the schools.

terventions based on pedagogical content knowledge that might contribute to successful secondary education in these subjects for minority students. The application was honoured and in 1995, the project ‘Minorities in  $\beta$ -education’ (ABO-project) was launched. This project consists of three subprojects: mathematics, biology and science. This thesis represents the subproject for mathematics (ABOW-project), which was carried out at the Freudenthal Institute.

In August 1993 basic secondary education was introduced for all secondary schools in the Netherlands. Mathematics had a unique position in relation to the other subjects: in addition to this introduction, a new mathematics program was implemented<sup>1</sup>. This mathematics program had as its starting point, that it was possible to teach meaningful mathematics suitable for large groups of students. This approach is consistent with the didactical theory known as ‘realistic mathematics.’ The introduction of the new learning program had a number of implications for mathematics education. For instance, the importance of language within mathematics education had increased: the growing number of contexts made the subject more language-based, while students also required to talk more, listen to each other and consult each other. This put a great strain on the vocabulary and communicative abilities of both students and teachers.

The students also needed to actively work with mathematics: they were no longer not passive consumers, but active participants who constructed their own mathematical tools and insights during the educational process. Other than in traditional mathematics lessons, students in realistic mathematics education were expected to justify their solving strategies, listen to others, try to understand different strategies, and when necessary, ask for clarification and enter into discussions.

## 4.2 Formulating the first research questions

The research began a few years after the new mathematics curriculum was first introduced. The design for the new books that went with this new plan were based primarily on the principles of realistic mathematics education (RME). At the start of the research this situation, with the new plan and the new books, was the starting point for formulating the following research questions:

- a How do minority students function within (realistic) mathematics education and what problems do they encounter?
- b Which didactical interventions contribute to successful participation in (realistic) secondary mathematics education by minority students?

---

1. This mathematics program is known under the name *Wiskunde 12-16* (‘Mathematics 12-16’; see among others team W12-16 (1992)).

We chose to approach this problem from the educational setting in which the minority students exist, in other words, the current classroom situation in which they find themselves. The questions investigated through this study were ‘why do minority students not perform as well as non minority students?’ and ‘what can you do about these results?’. The question of ‘why’ is investigated at in the perspective of ‘what solutions will provide the necessary support?’. More specifically, we were looking for factors that could be influenced. Because we do not want to limit ourselves to an inventory of possible factors, but also want to know how these factors influence the attitude and actions of students and teachers, we will use the more dynamic term ‘mechanism’ in this thesis. We see a mechanism as an effect, property, behaviour, or a combination of all these, that explains why certain student characteristics lead to a certain result.

This resulted in the following question:

- c Which mechanisms seem promote to an educational disadvantage in mathematics for minority students in relation to native Dutch students?

### 4.3 Description of the data collection

#### *Subjects*

The research was limited to minority students in basic secondary education. Special types of education, such as schools that work with newly-arrived immigrant children or children of asylum seekers were not taken into account. Also, the selection was limited to those students where *both* parents were born in either Turkey, Morocco, or in Surinam, the Dutch Antilles or Aruba. Analogous to this definition, for this research we identified Dutch students to be those students of which *both* parents were born in the Netherlands.

#### *Collecting data*

At the beginning of the research it was difficult to choose a point of departure. To get an impression of the problems minority students have and to get a first impression of the practice of mathematics education in multicultural classes, a *literature study* was conducted and visits were made to multicultural schools. During these visits *orientation observations* of 16 mathematics lessons took place, as well as 14 *interviews* with mathematics teachers, minority counsellors and mathematics students. After this orientation period, we decided to concentrate on the aspects of ‘language’, ‘contexts’ and ‘reasoning’, based on the suspicion that those would be the areas in which indications could be found to explain the lagging results of minority students. We wanted to research this in the regular classroom situation in which the minority students were working. We followed the working hypothesis that the problems mi-

minority students experienced and the mechanisms that caused these problems, would become visible during interactive mathematics teaching. We define ‘interactive mathematics teaching’ as an exchange of ideas takes place when both the teacher and the students present their solutions and points of view, and the participants in the interactions evaluate each others input and react to each other.

Alongside the observations a *written mathematics assessment* was presented to 227 first year secondary school students. The results of this test led us to the assumption that minority students get wrong answers more often than Dutch students because of incorrect interpretation of questions, rather than because of being incapable of performing the requested calculations. Furthermore, it is striking that minority students used a scratch paper less often than Dutch students and more often do not put down any answer at all.

From the orientation observations, it turned out that there was little interaction in the sense mentioned earlier in regular mathematics lessons, which meant that approaches and possible problems of minority students only revealed occasionally. The general impression of the mathematics lessons was that of a teacher who sets out a learning trajectory, and students who try to follow the teacher without taking an active role. Students do not ask many questions during whole-class moments. Simple observations failed to yield enough information, so a decision was made to intervene in regular mathematics teaching by performing two *class experiments*. The first purpose of these experiments was to get the students to talk, still operating under the assumption that this would reveal problems and difficulties experienced by minority students. However, it turned out to be very difficult to have class discussions in which the students verbalized their problems and in which an exchange of strategies by students occurred.

Problems and approaches of minority students were easier to identify when students were working in small groups and from analysis of their written work. During the interviews, minority students mentioned that they regularly run into difficulties, and they described how they handle things that are unclear to them both during mathematics lessons and when working on problems. The observations of problems experienced by minority students only seem to be minor incidents, but they do connect to the literature and to what students are describing during the interviews.

This process helped us to better understand how minority students view mathematics, and how they handle problems experienced in mathematics lessons and while working on mathematics took shape. In order to be able to say in how far these assumptions can be generalised to all minority students, a written questionnaire was developed, which was presented to 448 first year secondary school students. In this questionnaire, the students were faced with a list of statements, and they were asked

to indicate on a 'Lickert' scale of 1 to 5, to what degree they agreed with these statements. From the questionnaire, it seemed that the image minority students had of mathematics was consistent with the ideas on which realistic mathematics education was based. Minority students do see, more than Dutch students, mathematics as a subject where you can get good grades by working hard, practicing a lot and learning things by heart. It was something of a surprise that minority students indicated that they asked the teacher for assistance when they ran into problems and during whole class discussions, since this was rarely seen during the class observations. Our observations find that most minority students took a passive role in the classroom. This led to the decision to re-analyse a number of protocols, this time from the question of whether we could understand why minority students did not ask questions during whole class discussions. This renewed analysis of the protocols brought to light mechanisms that helped explain the students' reluctance to ask questions.

From the first two teaching experiments, it turns out that the combination of observations with interviews provided the greatest insight into minority students' problems and attitudes. For this reason this combination was chosen for the *two final teaching experiments*. Furthermore, we decided no longer investigate whole class discussions and instead concentrate on conversations with and between minority students who were working on mathematics problems. This approach brought to light approaches used and problems experienced by minority students while working on mathematics. The conversations with and between minority students who were working on mathematics problems, clarified how minority students reach incorrect answers as a result of misinterpreting the used words or contexts.

#### **4.4 The research process illustrated**

Initially, the analysis of protocols and student material looked at the *student's* role. Then the analysis looked at what the *teacher's* role, and next an attempt to understand *student* behaviour was made. Slowly, a picture emerged of where and how minority students may run into problems. Subsequently, these results were linked back to earlier observations. In this way we formulated a number of mechanisms that explain how minority disadvantages originate and continue to exist.

The entire study was an explorative process, and can be seen in figure 4.1.

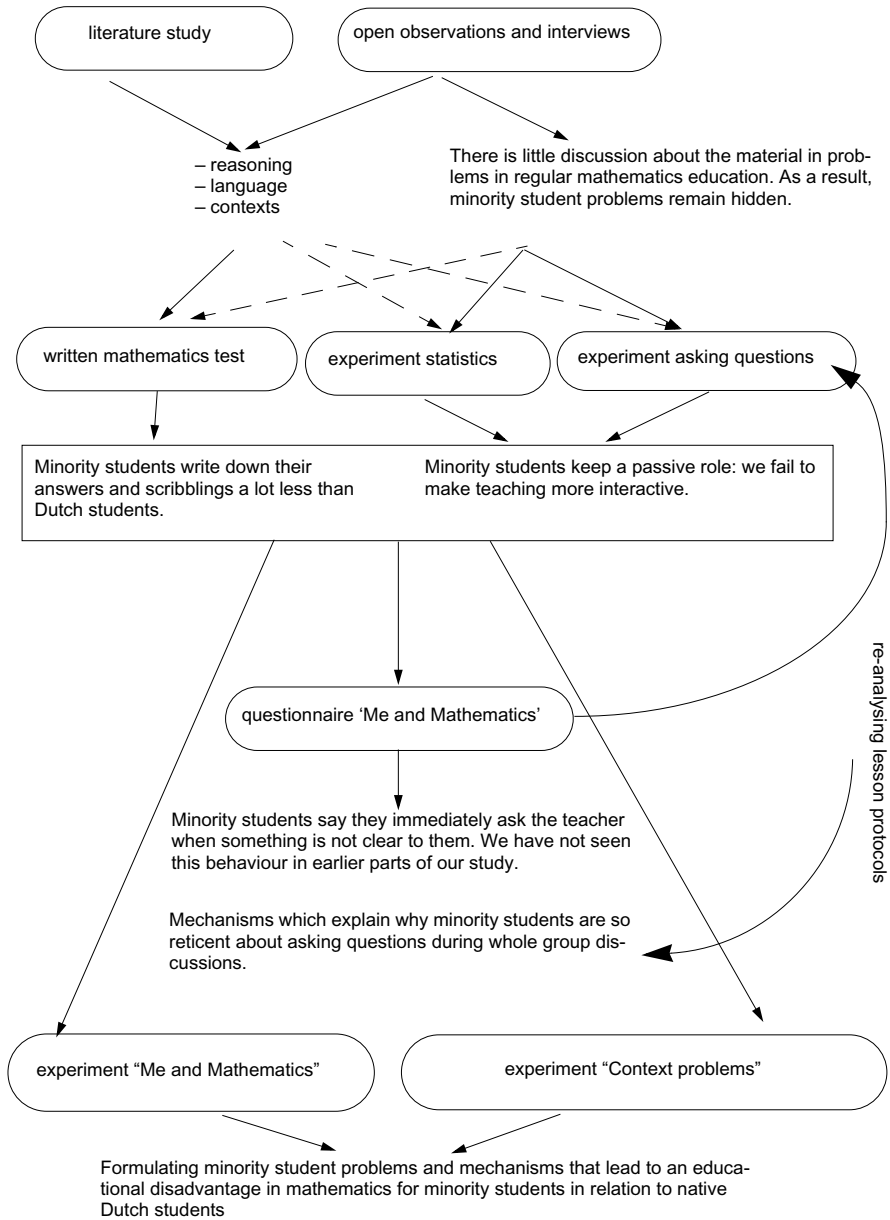

figure 4.1 The research process illustrated

## 4.5 Answering the research questions

We will follow the thought process we went through in our research for our description of the answers to the three research questions: a description of the way minority students function in mathematics lessons (research question a), is followed by a description of some mechanisms that lead to an educational disadvantage for minority students (question c). We will finish this summary with didactical recommendations (question b).

### *Research question a:*

#### *the way in which minority students function in mathematics lessons*

After conducting a literature study and visiting multicultural schools, three aspects were identified which were expected to cause problems for minority students. These areas were the aspects of *language*, *contexts* and *reasoning*.

In interviews minority students only gave *language* related problems as examples. Furthermore, they commented that they do not experience the use of unfamiliar words as taxing as long as it did not stop them from reaching the correct answer. However, during observations and while working with students we observed that with some regularity students reached wrong answers as a result of difficulties with statistical terms ('range'), school jargon ('show', 'explain') or as a result of incorrect interpretation of a concept because of the context in which the concept was used.

The analysis of difficulties resulting from the use of *contexts* brought to light difficulties that could be traced back to language problems. The minority students will, as a rule, concentrate on those text fragments that they think are important and contain the necessary data without studying the context further. They get to work on the data, and as a result, often end up with incorrect answers. Finally, context problems often use illustrations, which are quite often interpreted incorrectly or ignored by minority students, which will lead them to incorrect answers.

We also looked for an answer to the question of whether minority students have more problems with setting up a line of *reasoning* than Dutch students. We found no indication of this in the research, but it should be noted that during the research attention shifted more and more to possible language problems or problems resulting from the contexts used. We did observe that minority students made much less use of the space reserved for scribbling notes on their test papers, and we observed also that minority students failed to write down an answer more often than Dutch students.

As well as possible problems experienced by minority students, we examined the way minority students behaved in class. We will get back to this when answering research question c where we will go into mechanisms that explain the disadvantages of minority students compared to Dutch students.

*Research question c:**mechanisms that lead to educational disadvantages for minority students*

It can be deduced from the above description that among other things, language problems and lack of contextual knowledge lead to minority students' ineffective (learning) strategies, resulting in lagging performances in mathematics. However, class observations hardly bring to light minority students' problems during regular mathematics lessons, and as a result, neither the teacher nor the student can fix or prevent these problems.

When we combined all findings and analyses from the sub studies, we found that a cause for problems remaining hidden was due to an interaction of students' ideas and the mathematics teacher's teaching methods. We speak of mechanisms to clarify the previous. These mechanisms lead to the following situations:

- 1 Minority students assume text problems are not important.
- 2 Minority students do not feel encouraged to ask questions, and if they do ask questions they do not feel encouraged to clarify their problems.
- 3 Minority students' problems remain invisible.

Figure 4.2 gives a schematic view of this process.

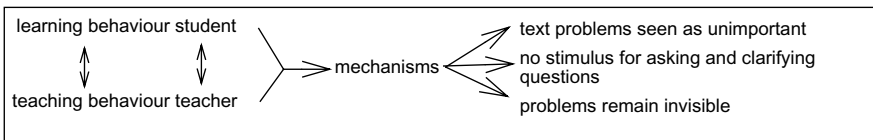

figure 4.2 Schematic overview of how mechanisms work

In the following, we list a number of characteristics of the learning behaviour of minority students and of the teaching behaviour and expectations of the teacher for various situations which emerged from the research. Subsequently, we will describe how the combination of these aspects forms the mechanisms that leads to the situation as described.

1 *Minority students assume text problems are not important*

The learning behaviour of minority students:

- minority students are familiar with text problems;
- minority students focus on calculations and answers.

*Mathematics teachers' teaching behaviour and expectations*

- teachers decontextualise context problems.

Minority students are familiar with text problems, and are therefore not distracted by the use of unfamiliar words in the text. The most important aim for the students is finding an answer to a problem. When the teacher subsequently puts an emphasis on finding the requested calculation in whole class discussions about context problems, this approach matches the minority students' learning strategy and they will copy this. Leaving the context behind as soon as possible will become the standard. As a result, when faced with a context problem, minority students will go to work with the numbers without attaching meaning to those numbers. When the student performs the most obvious operation and finds an answer, the problem will be solved as far as the student is concerned. If the answer is correct as well, there will be no reason for either the teacher or the student to check whether the student interpreted the problem and the context correctly. The minority student is reinforced in his strategy of ignoring unfamiliar text. If the answer is wrong, and it turns out that this is because of a wrong interpretation or by ignoring an important term, this does not have to be immediately apparent. The teacher may explain the problem again, mentioning the term in question, but without giving specific attention to the term. The student can understand the explanation and decides that he could have solved the problem since he 'just didn't read it correctly.'

2 *Minority students do not feel encouraged to ask questions, and if they do ask questions they do not feel encouraged to clarify their problems*

Minority students learning behaviour:

- minority students find a final explanation sufficient;
- minority students have strategies to handle unfamiliar words;
- minority students do not realise they are having problems.

Teachers' expectations and teaching behaviour:

- teachers explain;
- teachers subconsciously send out the message 'do not ask questions';
- teachers discuss some terms only casually;
- teachers have or take too little time to discuss contexts and different solutions with the students.

When a teacher takes on the role of interpreter, minority students tend to fall into a passive role. Their input is limited to answering the teacher's questions, where they try to give the answer they suspect the teacher has in mind. The students do not feel encouraged to actively think about how to solve problems and will therefore not ask questions when they feel they can, in the end, obtain the right answer.

When a teacher state a problem or idea is easy, can be interpreted by the students as

‘do not ask questions’. As a result, the students will be reticent about asking questions, which the teacher will in turn interpret as ‘the students have no questions; everything is clear to the minority students as well.’

When the teacher only discusses a term in passing, it is not always clear to the minority student whether or not the term is important. When the minority student does not understand the meaning of the word, but decides that the word is not important, he will not ask any further. When a word does seem important, minority students use strategies they have learned or developed for finding out the meaning of unfamiliar words: re-reading the text or making use of illustrations and context. When the student feels he has found the correct meaning he will no longer ask questions.

What can also happen is that the minority student does not ‘hear’ the discussion of the term, because no explicit attention is requested. The student does not ask anything, and the teacher assumes the student understood everything the way he meant it.

When a teacher does not have or take the time to discuss contexts and possible interpretations of problems and solutions with the students, there is a great chance that possible misunderstandings remain. When the students themselves have not spoken and provided their own input, uncertainty remains over what exactly they have understood.

Asking the students at the end of an explanation whether they understood or whether they still think the subject is difficult also is not enough. After all, for the minority students the standard is that finding the final answer and having a global understanding of the given reasoning is enough. However, when the students nod that they understand, or do not say anything, the teacher will interpret this as there being no questions, and that the students understand the material, and he will continue his lesson.

### 3 *Minority students’ problems remain invisible*

Minority students’ learning behaviour:

- minority students do not ask questions;
- minority students talk in short sentences;
- minority students write down very little.

Teaching behaviour and teachers’ expectations:

- teachers expect that minority students will ask questions;
- teachers adapt their language and demands to minority students.

In the questionnaire they were asked to complete, minority students indicated that they asked questions when they did not understand something. However, in practice they asked very few questions and often failed to recognise the problems

they were having. When no questions were asked, the teacher (sometimes incorrectly) concluded that the explanation was clear and that the students understood it. As a result, the teacher would progress on to the next topic. Whether the topic was understood correctly by the student, does not come to light.

Teachers display accommodating behaviour towards minority students: they have a tendency to replace jargon with day-to-day language in their explanations and the acceptance of imperfect explanations by minority students becomes the standard. As a result, minority students are not stimulated to develop mathematical language for themselves. Also, the teacher will interpret the student's question or comment within his own frame of reference: the teacher has certain expectations of what a minority student's question or reply will be, and he matches his reaction to that expectation. This is also the case for interpreting students' short written answers. The question remains of whether the teacher understands what the student really meant.

*Research question b:  
interventions based on pedagogical content knowledge*

We cannot yet answer this research question ('which interventions based on pedagogical content knowledge can contribute to successful participation in secondary realistic mathematics education by minority students?'). There have been some interventions in the teaching-learning process, but these were aimed at actively involving minority students in the lessons, based on the assumption that in that way possible problems and approaches of minority students become visible.

What we can do is formulate a number of recommendations for the teaching of minority students, based on the findings of this research. These recommendations must be seen as hypotheses, since no research has yet been done into whether these recommendations lead to an improvement in minority students educational achievements. The underlying aim of the recommendations is to influence minority students' learning strategies, and especially their way of participating in lessons.

- 1 There must be a change in the roles of teacher and students that gives minority students an active contribution to the teaching-learning process.
- 2 Minority students benefit from more complex problems: problems that challenge them, that make them engage in discussion, find and formulate their own solutions.
- 3 An environment must be created in which sufficient time is provided to minority students to discuss problems and possible solutions, and then to write down their own ways to solve the problem.
- 4 In class, attention must be given to the terms used. We recommend that teachers explore terms that are necessary for solving a problem or understanding (mathe-

mathematical) concepts with the students in such a way that the students have an active role. This would give both teacher and student a chance to verify correct interpretation of the term. Moreover, the student is forced to actively use (mathematical) language.

- 5 Attention must be paid to the use of illustrations when putting together problems.

## 4.6 If you know what I mean

One explanation for lagging achievements by minority students is the number of mechanisms we described, which arise from an interaction between minority student problems, teachers' teaching behaviour and minority students' learning behaviour. Learning through problem solving, reasoning and reflecting all have a central place in Dutch mathematics education. However, minority students often assume a passive role due to their lack of linguistic skill and therefore concentrate on calculations and answers. They learn little from their own mathematical activities and are satisfied with an instrumental understanding.

We are of the opinion that minority students' educational disadvantage can, at least partly, be explained by the fact that these students' learning strategies are not effective in mathematics education. As a result of their strategy, their problems do not come to light. Teachers and students believe they are talking about the same thing, when in reality they each have a different idea in mind. When the minority student reaches a correct answer, both teacher and student believe that the learning process was successful.

To more clearly reveal these misunderstandings, an intensive form of interaction between teacher and student and between students is essential. Only then will possible problems come to light and will minority students be given the chance to develop mathematics and (mathematical) language for themselves.

Finally, a recommendation to teachers and students, as well as researchers: when communicating with others, do not assume too soon that you share the same definitions for the concepts and expressions in discussion. Do not draw the conclusion 'you understood it precisely', but always add - at least mentally: 'if you know what I mean.'

## References

- Suhre C., W. de Wit & L. Mulder (1996). *Onderwijsachterstanden in het voortgezet onderwijs. Eindrapport schoolloopbanenonderzoek OVB-cohort 88-8*. Nijmegen/Groningen: ITS/GION.
- Team W12-16 (1992). *Achtergronden van het nieuwe leerplan. Wiskunde 12-16 band I*. Utrecht / Enschede: Freudenthal Instituut / SLO.
- Wit, W. de, C. Suhre & L. Mulder (1993). *De onderwijspositie van de OVB-doelgroep leerlingen na drie jaar voortgezet onderwijs*. Nijmegen: ITS.
- Wit, W. de, C. Suhre & L. Mulder (1996). *OVB-doelgroep leerlingen in het voortgezet onderwijs. Deel 2: de onderwijspositie van cohort 92-8 in het tweede jaar*. Nijmegen/Groningen: ITS/GION.

---

## 5 Reinvention of early algebra

*Barbara van Amerom*

### 5.1 Introduction and research problem

This chapter reports on the research project ‘Reinvention of algebra’, which was carried out in 1995 - 2002. In this section, we describe the background of the research with a description of the research problem. Then a survey of the learning problems associated with algebra is presented, followed by a sketch of the history of algebra and the design and methodological issues of the study. An account of the design process of the experimental learning trajectory is provided. Finally, the results are presented and discussed.

What are the considerations underlying the research ‘Reinvention of algebra’? Algebra education is currently the focus of much attention. One of the issues which teachers, researchers, developers and teacher educators are concerned with is why so many children experience such difficulty using letters while calculating. Years of discussion have been invested in an attempt to grasp this problem more sufficiently. To solve the learning problems, the following questions have been explored: To what extent does algebra differ from more rudimentary calculations? When and how should students be introduced to which algebraic topics? No unequivocal answer has yet been given to these questions, a point that motivated research into whether it would be possible to devise a new instructional approach in which the connection between calculation and algebra figures prominently.

A second stimulus of this research emerges from the increasing interest in the incorporation of mathematics history in the classroom. While there is evidence that elements of history in education can positively influence student interest and involvement, it remains to be seen whether including history would play a significant role in developing mathematical insights.

Combined in a single research project, ‘Reinvention of algebra’ addresses both aspects: the learning difficulties encountered in introductory algebra and the didactic value of mathematics history. Based on a series of lessons on equations for eleven to fourteen-year-olds, development research has been conducted into making the transition from arithmetic to algebra and the role history could play in this transition.

### 5.2 Problems of learning algebra

This section describes the problems associated with learning algebra and specifically the transition from arithmetic to introductory algebra. Over the past decades, numerous researchers have written on the nature of algebra, which topics of algebra belong in a learning trajectory at least and the manner in which students ought to start learn-

ing algebra. From the work of Kieran (1989) it appears that no unequivocal opinion on these issues exists, but rather that a classification of algebraic features would be worthwhile and useful for discussions about algebra education. Bednarz et al. (1996) distinguish four different approaches to algebra: generalizing, problem solving, modelling and the functional approach. Learning algebra through generalizing is based on an expansion of mathematical knowledge of numbers and the relationships between them. Employing problem solving as a way of approaching algebra emphasizes formulating and solving equations. In modelling the mathematical description of daily phenomena is central, and variations in representations - graphs, tables and formulas - are featured prominently. As with working with functions, relationships between variables play an important role here. The didactic capacities of computers and calculators are investigated with regard to the role they could play in algebra as the study of functions. Bednarz et al. (1996) hold this classification as rigid and incomplete and that each of the four themes requires further division.

The principal learning difficulties experienced by students of early algebra relate to the transition from arithmetic conventions to those of algebra, the meaning of literal symbols and the recognition of structure. Frequently mentioned obstacles are the meaning of the equality sign, the conversion of a description into an equation or a system of equations, and the manipulation of symbolic forms. Sfard (1991) partially attributes these learning difficulties to the fact that mathematical concepts can be understood in two fundamentally different ways: as *processes* and as *objects*. She hereby differentiates between a so-called operational conception and a structural conception. In algebra symbolic forms have to be seen as processes on the one hand and objects on the other. For example the form  $3x + 5$  can mean 'multiply  $x$  by 3 and then add 5', a process. Meanwhile,  $3x + 5$  stands for the result of the calculation, thus an object. Considering the fact that in arithmetic a student only encounters the operational concept, we can speak of an obstacle in the learning process for algebra.

In the current primary school arithmetic-mathematics curriculum in the Netherlands, pre-algebra is occasionally introduced; and if this is done, it is done so cautiously. Nevertheless, this does not occur systematically. Arithmetic as an opportunity to introduce algebra fits the students' level in grade 6, and this allows for the use of historic sources. Development through the ages shows that algebra had long been practised as 'advanced arithmetic' and that arithmetical questions can serve as an introduction to algebraic reasoning. Moreover history reveals that knowledge of symbolizing and algebraic jargon are not prerequisites for algebraic reasoning; so, with little preparation, students can start and in this way come up with their own abbreviations.

The starting point for the design of the experimental learning trajectory lies in the activities that could simplify the transition from arithmetic to algebra. As far as the level was concerned, the choices were restricted to linear relations and solving systems of equations presented in the form of a picture or a description. Of the topics

addressed, skills development included comparing quantities, symbolizing, reversing operations, pattern recognition and using multiple representations. When learning algebraic notation or symbolizing, it is crucial that the new symbols are, from the outset, meaningful to students.

### 5.3 The history of algebra

In opting to include the history of mathematics as a didactic tool, it is supposed that its use will positively influence education. History places the subject matter in a broader perspective. Students can discover what mathematics meant to the development and growth of humanity, and that they too can contribute to this process. By examining the history of mathematics, students are able to see how cultural and social factors influenced the development of mathematics as well as the connections between mathematics and other disciplines. Historical insights benefit not only students, but also teachers, developers and researchers. In so doing, they will be in a better position to forestall difficulties students are otherwise set to encounter. However, despite the growing interest in incorporating history into mathematics teaching and the positive experiences described in the ICMI study of history in mathematics education (Fauvel & Van Maanen, 2000), not much is known about history's actual contribution to the learning process. In this study, an attempt was made to explore what role history can play in developing mathematical insights in the area of introductory algebra.

Over the years, several discoveries and advancements have contributed to the development of algebra. Usually, three phases are distinguished, which correspond with the kinds of notation used: the rhetorical phase with descriptions in the natural language, the syncopated phase with descriptions accompanied by abbreviations and mathematical symbols, and the phase of symbolic algebra with the modern algebraic symbolic language. A rough overview of the course of developments in algebra can be seen in Fig. 5.1.

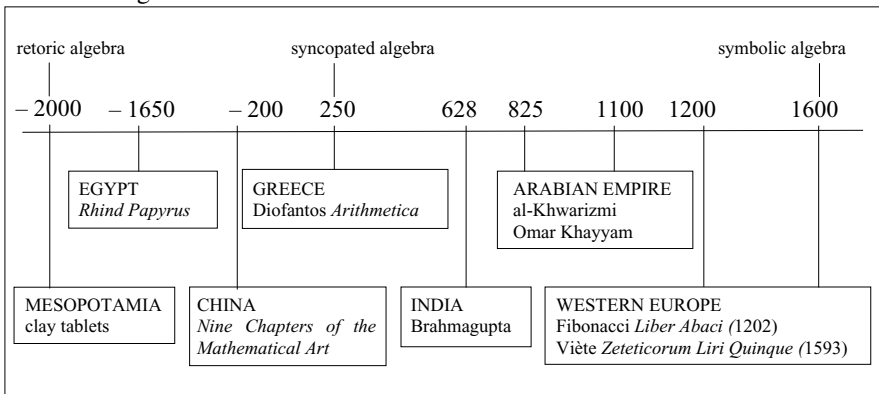

Figure 5.1 Phases in the development of algebra

Diofantos (250 B.C.) was the first to represent the unknown with a symbol and to calculate with it as if it were a number. From the thirteenth century onwards, syncopated algebra underwent continual development in Western Europe; in 1557 Robert Recorde introduced the current equality sign '=' to express equality. It took until the end of the sixteenth century for Viète to come up with the idea, which we are so accustomed to now, of symbolizing known as well as unknown numbers with letters. The algebra of the ancients could be characterized as an advanced way of solving arithmetic problems. The Egyptians and Babylonians were aware of a few ways of solving equations with one unknown, for instance the Rule of Three for proportion problems and the Rule of False Position for problems that can be reduced to the equation  $ax = b$ . The Chinese work 'Nine Chapters on the Mathematical Art' (ca. 200 B.C.) is the oldest known mathematical treatise which contains a description of a general method for solving a system of  $n$  equations with  $n$  unknowns ( $n = 2, 3, 4, 5$ ). Indian and Arab mathematicians - including Al-Khwarizmi whose work *Hisab al-jabr w'al-muqabalah* (ca. 825 A.D.) is the origin of the word 'algebra' - played an important role in advancing towards a systematic approach of solving equations. After 1600, when numbers could finally be expressed in letters, algebra became more than merely a means of solving mathematical problems and came to be a field unto itself within mathematics.

The history of mathematics has been an important source of inspiration in this doctoral research. In the experimental teaching materials, several important elements from the historical development of algebra were used.

- 1 In the teaching sequence, the emphasis was on solving word problems.
- 2 The activities can be described as 'advanced arithmetic' and dovetail nicely with the informal problem-solving strategies which primary school students have already mastered.
- 3 Bartering regularly plays a role as a natural and realistic context for comparing quantities.
- 4 Historical methods and problems invite students to consider the advantages and disadvantages of the various ways of solving problems.

## 5.4 Research design and methodology

The research questions of this study are:

- 1 When and how do students begin to overcome the discrepancy between arithmetic and algebra, and if they are hampered, what obstacles do they encounter and why?
- 2 What is the effect of integrating the history of algebra in the experimental learning strand on the teaching and learning of early algebra?

Using these questions as guidelines, two hypotheses are posited.

- 1 By way of pre-algebraic activities, students are able to bridge the gap between arithmetic and algebra.  
This hypothesis is based on previous research and a carefully considered course of instruction.
- 2 The history of mathematics positively affects the learning and teaching of introductory algebra not only because of the broader view of the subject matter, but also because of the mitigating pre-algebraic character and the meta-cognitive application of the historical methods and problems considered.

The research questions are divided accordingly into several subquestions. The subquestions in research question 1 refer to algebraic symbolization and the connection between the level of symbolization and the level of reasoning; in research question 2 factors such as age, sex, intellect and the teacher are explored to ascertain whether they wield any influence, and whether there are any relations between the algebra students develop (the individual learning process) and the historical development of algebra as a mathematical discipline.

The study is couched in the education theory known as Realistic Mathematics Education (RME). RME is characterized by the view that mathematics can be seen as a human activity, that people in mathematics education should build upon existing student knowledge and ability, and that various levels of mathematical problems ought to be solvable. Principles such as guided reinvention and didactical phenomenology play an important role in considerations surrounding lesson material.

The nature of the research can be characterized as developmental research. It is a combination of pedagogical research and design of student activities which results in a local instruction theory. In a cyclic process of theory and experiment, the learning trajectory is tested and adjusted several times; while reporting, it is essential, that the reader is able to track the researcher's learning process. The research 'Reinvention of algebra' comprises three complete cycles of design and implementation and several supplementary group activities. Fig. 5.2 (read left to right) illustrates the structure of the final research cycle.

The project is best described as 'exploratory' research considering the emphasis on the experimental phase of the development research, with a provisional design, small-scale experiments and the development of a number of theoretical ideas. Further research is necessary to arrive at a definitive learning trajectory and an empirically grounded instruction theory.

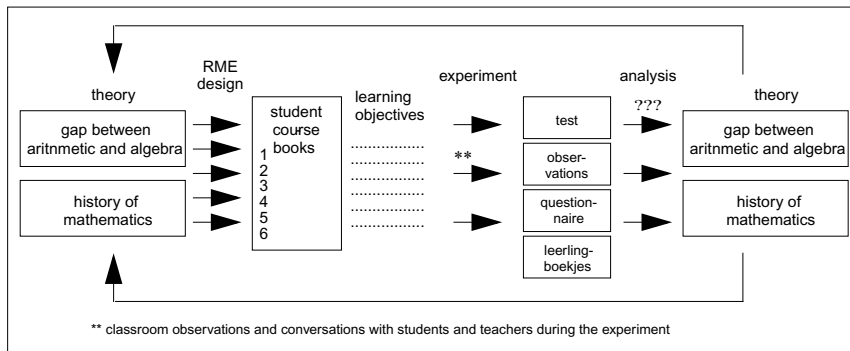

Figure 5.2 Structure of the final research cycle

## 5.5 Design of the learning trajectory

Let us now describe the process of designing the experimental learning trajectory. The first ideas for the course material originate from three sources: the history of mathematics, the algebra learning trajectory in the Mathematics in Context Project (Mathematics in Context Development Team, 1998) and a number of Streefland's (1991) teaching experiments. A mathematical didactical analysis of solving equations has revealed a core of skills and insights which serve as required foreknowledge for learning algebra; this analysis led to the design of a series of mathematical activities for students in primary school and middle school, in particular for grades 6 and 7. In the first teaching experiment, activities were tested with student pairs from grade 6 and then modified for use in a number of student text booklets. These booklets were subsequently tested in two classes and thoroughly evaluated. The initial round of testing was primarily intended to elicit feedback on the activities' attainability and suitability, whereas the second cycle was meant to compare the intended learning process with the actual learning process that took place in the classes. At the same time, several lessons about solving systems of equations and about a number of pre-algebraic methods and problems from mathematical history were taught in a grade 7 class.

The most noteworthy conclusion from the teaching experiments in the primary school indicates that students developed algebraic reasoning and symbolizing as separate skills. Reasoning came more easily to most students than symbolizing; in particular activities concerning amount comparisons and substitution of barter rates went well. In contrast students seem to interpret symbolic forms which were derived from self-devised own productions as a sort of shorthand notation, as opposed to a notation for generalized arithmetic. Accordingly the connection '3 more than' is symbolized as  $dB = +3 dA$  instead of  $dB = dA + 3$ . Through incorrect use of the equal sign and reversed interpretations of calculations, most students seem to get stuck in a procedural way of thinking. Working with tables is nowhere near self ev-

ident for students as might be expected, to the extent that introducing tables as an aid to the reasoning process does not get off the ground. Additionally, reasoning about relationships between quantities remains out of reach for most students.

Experiences from grade 7 are more positive, although here too all manners of imperfections in symbolizing were observed. Students are not prepared to symbolize as readily as expected; unknowns were mostly omitted. There is a strong inclination to shorten into a syllable, and the equal sign is primarily understood in the procedural sense, namely as an announcement of a result. Only a handful of students masters the formal level of symbolizing. The experiment also demonstrated that informal strategies of solving equations, such as repeated exchanges and the composition of new combinations, allow for a transition from arithmetic strategies (clever attempts) towards a more formal approach. Some students find the pre-algebraic calculation techniques from history useful and/or novel, but most students prefer a modern approach.

After completing the second research cycle, an evaluation of the research design and the experimental teaching material was conducted by field experts. This gathering was very influential on the remainder of the research. Important decisions were made on four different points.

- 1 Some experts were unable to recognize the research objectives and research questions in their implementation.
- 2 To maintain the didactic significance of the history of mathematics as a research component, history should have a more explicit presence in the teaching material.
- 3 The proposed use of literal symbols in the teaching materials met with great resistance because the difference, so essential in algebra, between numbers and quantities was not clarified.
- 4 The activities were inadequately problem orientated.

These points were assimilated into the final version of the teaching material, which drastically altered the mathematical content as well as the student activities.

## 5.6 Results

There are three levels of research results to distinguish between: student results, researcher reflections, and relevance and consequences of the findings. This section focuses on the first two categories, the third is addressed in the next section.

Student results consist of written test results, work from course books, lesson observations and individually completed questionnaires. Three conjectures emerged from the analysis of the student answers to the test 'Flash cards', and these conjectures were subsequently tested in practice with other problems:

- 1 Reasoning versus symbolizing
  - a Students are capable of choosing or discovering a path from arithmetic ways of solving problems to algebraic ways, irrespective of intermediate pre-algebraic strategies and/or representations;
  - b Students who have difficulties arriving at an algebraic way of thinking (from an arithmetic way of thinking) mostly seem to get stuck in an arithmetic level of notation;
  - c Pre-algebraic and algebraic notation is not necessary for algebraic reasoning, but appears to support solving pre-algebraic and algebraic problems.
- 2 Setbacks in the level of solving
  - a The general applicability of algebraic strategies increases the risk of superficial knowledge, which entails students reverting to lower levels of problem solving;
  - b The chance of experiencing a setback is greater for girls than for boys.
- 3 Understanding connections

Mathematical notions of numbers and connections between numbers impede the development of algebraic understanding.

The result of these conjectures, taken with other findings in the student work, answers the subquestions, and therefore the two main research questions.

The three components of the supposition on reasoning and symbolizing are all endorsed in the analysis. Student work demonstrates that algebraic reasoning is more accessible to students than algebraic symbolizing. Moreover, both skills can be verified as two independently manifesting skills in the process of learning of algebra. It appears to follow then that developing algebraic thinking is not necessarily dependent upon algebraic notation and that the presence of algebraic notation says little about the level of problem solving, although advanced notation is more often than not an indication of a good solution. In keeping with the findings from earlier experiments, students tend to rarely employ schemes and tables to support their reasoning. Consequently, it seems that part of the teaching sequence was unattainable for the average student. In contrast to the aforementioned conjectures, a setback in the level of problem solving does not demonstrably occur more often in algebraic strategies than in mathematical ones, nor are there perceptible differences between boys and girls in this area.

A number of observed peculiarities in student work suggests some arithmetic conventions caused misunderstandings of relations between quantities. Because students are accustomed to calculating with established quantities, they experience problems reasoning about (relations between) unknowns. Primary school students in particular have little grasp of the requirement of equality when using the equal sign. The third conjecture for the analysis is thus demonstrated.

The added value of mathematical history for teaching introductory algebra was more apparent in grade 7 than in grade 6. The activities concerning the Rule of Three and the Rule of False Position stimulated grade 7 students to think about their own strategies. Additionally, some activities - the Diofantine riddles about sum and difference and Calandri's fish problem - brought forth pre-algebraic methods and notation which facilitated the transition from an informal to more general approach. As far as the student reactions are concerned, grade 7 students clearly evaluated the historic problems more positively than the grade 6 students. The weaker students in particular were distracted or discouraged by what was for them unusual question formulations.

Student work reveals that the unknown has a remarkable function in the informal solving of (systems of) equations. Letters and symbols help students organize the information in a problem, but the unknown does not play a meaningful role in the solution process. One of the driving forces underlying this doctoral research project was the recapitulation as well as the reinvention of algebra along historical lines. Besides the habit of not including the unknown in the calculations, there are two other correspondences to point out between the historical development of the topic on the one hand and the learning process of the individual on the other: descriptions with words and abbreviations enjoy the upper hand in introductory algebra and linear equations with one unknown can be solved using ratios. Additionally students devised a number of strategies for solving problems of sum and difference which deviate from Diofantos' approach. The analysis of student work and learning processes in the class yielded the following answers to the research questions:

- 1 The gap between arithmetic and algebra can be bridged partially with the aid of some pre-algebraic strategies and informal ways of symbolizing, but not by all students. Students may also skip the pre-algebraic phase altogether. Sometimes students consciously cling to an informal approach, especially in situations where it is (nearly) equally as effective as a more advanced approach. In other words, pre-algebraic aptitude does not automatically lead to more formalization. Children who cannot seem to overcome the arithmetic level in terms of reasoning often get stuck at a lower level of notation.  
Some of the obstacles students encounter in the transition from arithmetic to algebra are the use of schemes and other forms of representation to support mathematical reasoning, the recognition of isomorphic problems, symbolizing the unknown, misunderstandings about (unknown) quantities and the relations between them, and a flexible way of thinking about literal symbols.
- 2 The integration of mathematical history in the experimental learning trajectory affected the grade 7 class more than the grade 6 classes. In the grade 7 group -

thanks to the teacher's greater degree of involvement amongst other factors - there were more opportunities for reflection, and the students had a more engaged learning disposition than in grade 6. Some problems and methods from the history of algebra fostered spontaneously successful pre-algebraic strategies in class. Some relations confirmed between the historical development of the course material and the individual as well as the collective learning process in the class provide new ideas for teachers, developers and researchers.

In conclusion we notice a difficulty in tailoring algebra education according to the principles of RME, the role of the teacher and the disposition of students when confronted with writing out calculations.

## **5.7 Discussion and recommendations**

This final section examines the research results and makes a number of recommendations for future development and research work.

In this research it is clear that, in grade 6, shortened notations come with a number of complications. Generally recognized problems such as the inaccurate use of the equal sign, the so-called 'reversal error' and the meaning of literal symbols also came to light in this study. Many students read formulas as a sort of shorthand. Apparently no connection was made between the description '3 more than' and the action 'add 3', which is a requirement for a double perspective- the process and the object perspective. Attempts with barter rates succeed in correctly symbolizing the dynamic aspect of relations between quantities, apparently from the trade activity, but then the letters do not function on an algebraic level (as variables) but on an arithmetic level (as abbreviations). Nonetheless it may be possible to introduce formulas with dynamic, procedural action language such as the arrow notation, in order to better build upon arithmetic foreknowledge. Additionally the mediocre functioning of schemes, tables and number strips as reasoning tools suggests that students in remaining sessions ought to be more actively involved in the introduction and the development of similar aids.

Fewer problems in symbolizing occurred in grade 7. In accordance with Harper's (1987) findings, the older students are more open to algebraic notions. The spontaneous shortening of notation usually leads to a combination of symbols, abbreviations and words, but symbolizing of an unknown quantity did not pose much of a problem for grade 7 students. The most noteworthy result is that the unknown is rarely if ever included in the calculations, a feature that was quite common in the distant past. Symbolic notation is occasionally manipulated at a formal level. The observation that symbolizing and reasoning more or less develop in students as independent skills is in keeping with Krutestkii's (1976) observation that some students are visually inclined while others primarily use mental processes. Moreover he verified that high achieving students are better able to reason than to symbolize. At the same time,

various researchers argue for mathematical activities that combine both aspects precisely because symbols receive meaning when they are employed in problem solving.

The fact that research revealed that a considerable number of students demonstrated a lower level of problem solving in the test than what they had achieved during the lessons was often, though not always, a sign of weakness. Particularly students who seemed to have mastered the elimination of the unknown in the lessons were unable to solve a test problem or only managed to do so through a trial-and-error procedure. Apparently these students were unable to draw upon the pre-algebraic solution method. Only occasionally does a student consciously opt for an informal approach. Viewed from the perspective of meaningful mathematics, it is important that the opportunity exists to repeat covered materials. Other research into solving equation reveals that students occasionally unlearn earlier skills, and that children who have mastered both the formal and informal strategies perform better.

Research results reveal that the transition from arithmetic to algebra is hampered by differences between arithmetical and algebraic ways of solving problems, by common mistakes in using a variable and by the contrast of static as well as dynamic understanding of connections between quantities.

Booth (1984) describes six properties of arithmetical strategies which obstruct the development of algebraic thinking; the emphasis falls on that which is specific as opposed to that which is general and the absence of symbolizing. In their analysis of arithmetic and algebra problems Bednarz and Janvier (1996) remark that algebra problems are less cohesive than arithmetic problems - students are immediately able to identify the unknown using the given information in the latter. As a result of this difference students approach the algebra problems with the wrong information; this is one of the mistakes that clearly stood out in the research. Bednarz and Janvier identify two other obstacles that play a role in this research: the aversion to symbolizing an unknown quantity (in grade 6) and the so-called 'reversal error' which refers to the reversed understanding of the relation between two quantities. In contrast students in the grade 7 class were successful in manipulating symbols to a certain extent, and both grade 6 and grade 7 students were successful in dealing with substitutions and simplification of symbolic forms (with barter rates and linear equations with one unknown).

The difficulties observed in this research that concern the statistical and dynamic (procedural) view of quantity and relations are in keeping with the addressed learning difficulties associated with algebra, as discussed in Section 5.2. The mediating role of some pre-algebraic solution methods and notations provides the following clues for a learning trajectory that would attempt to bridge the gap between arithmetic and algebra.

- 1 The student activities on systems of equations developed for this study led to a flexible use of informal strategies and notation and a natural transition to the process of elimination.
- 2 The number of approaches observed in the Flash cards test forms a small-scale learning trajectory.
- 3 The teaching experience with the problems concerning the Rule of False Position suggests a succession of activities which could ultimately lead to insightful solutions to linear equations with one unknown.

Based on the results of this research, we make a number of recommendations for developers and teachers. Symbolizing should receive more attention in primary school, especially as a support for mental processes. As far as shortened notation is concerned, it is advisable to build upon knowledge of arithmetic; formal algebra notation conflicts with arithmetic conventions too much. The emphasis should be placed on dynamic action language. We would also argue for more activities that draw upon skills such as structuring and schematizing, so that tables and other schemes can evolve into aids in mathematical reasoning. Students should have more practice reflecting upon their own ways of working so as to increase their drive to improve. Do not allow the learning difficulties associated with algebra to fall by the wayside, instead seize them as discussion opportunities; make students aware of the ongoing conflicts. As far as the integration of mathematical history into the curriculum is concerned, we propose differentiating along the lines of student level to plan group activities and we propose using the learning objectives and not history as a starting point.

The subjects within the learning trajectory that were not successful, the conjectures about the differences between boys and girls which could not be confirmed in this research, and the question of what is required of the teacher for the proposed experimental teaching sequence should be addressed in future research, which will ultimately lead to an improved expertise in the area of solving equations formally.

## References

- Bednarz, N. & Janvier, B. (1996). Emergence and Development of Algebra as a Problem-solving Tool: Continuities and Discontinuities with Arithmetic. In N. Bednarz, C. Kieran & L. Lee, L. (Eds.), *Approaches to Algebra* (pp. 115-136). Dordrecht/Boston/London: Kluwer Academic Publishers.
- Bednarz, N., Kieran, C. & Lee, L. (Eds.) (1996). *Approaches to Algebra*. Dordrecht/Boston/London: Kluwer Academic Publishers.
- Booth, L.R. (1984). *Algebra: Children's Strategies and Errors*. Windsor, UK: NFER-Nelson.
- Fauvel, J. & Van Maanen, J. (Eds.) (2000). *History in Mathematics Education: The ICMI Study*. Dordrecht/Boston/London: Kluwer Academic Publishers.
- Harper, E. (1987). Ghosts of Diophantus. *Educational Studies in Mathematics*, 18, 75-90.
- Kieran, C. (1989). The Early Learning of Algebra: A Structural Perspective. In S. Wagner & C. Kieran (Eds.), *Research Issues in the Learning and Teaching of Algebra* (pp. 33-56).

- Reston, VA: National Council of Teachers of Mathematics; Hillsdale, NJ: Lawrence Erlbaum.
- Krutetskii, V.A. (1976). *The Psychology of Mathematical Abilities in Schoolchildren*. Chicago: University of Chicago Press.
- Mathematics in Context Development Team (1998). *Comparing Quantities*. Chicago: Encyclopaedia Britannica Educational Corporation.
- Sfard, A. (1991). On the dual nature of mathematical conceptions: reflections on processes and objects as different sides of the same coin. *Educational Studies in Mathematics*, 21, 1-36.
- Streefland, L. (1991). *Fractions in Realistic Mathematics Education. A Paradigm of Developmental Research*. Dordrecht, the Netherlands: Kluwer Academic Publishers.



---

## 6 Design research in statistics education

Arthur Bakker

### 6.1 Introduction

The project ‘Symbolizing in statistics education’<sup>1</sup> reported upon here was carried out in 1998 - 2003. It is a case of research on the integration of information technology (IT) into education, and on its influence on the learning of mathematics in particular.

In today’s knowledge society everyone needs basic statistical literacy, and in many professions and scientific disciplines, solid knowledge of statistics is even needed. However, the necessary statistical literacy is mostly not gained in general education (e.g. Zawojewski & Shaughnessy, 1999). What is needed, therefore, is an empirically grounded instruction theory of how school-aged students can learn statistics. The purpose of the research presented here is to contribute to such a theory. As such, it is a sequel to research carried out by Cobb, McClain, and Gravemeijer (2003) and their team at Vanderbilt University, Nashville, TN, USA.

The methodology used was design research (e.g. Cobb, Confrey et al., 2003). In a cyclic process, a hypothetical learning trajectory (Simon, 1995) was designed, tested, and refined during classroom-based teaching experiments and the students’ learning process was analyzed retrospectively. At the start of the design research, the conjectured instruction theory had a hypothetical nature, but through the cyclic analysis and refinement, the developing instruction theory became empirically better grounded. The goal was not to design ‘the’ perfect statistics unit, but to understand how instructional activities and materials can support which kinds of statistical learning. In this research, two topics were central: symbolizing and computer tools. *Symbolizing*. In statistics, graphical representations play a central role, but without suitable concepts students can not interpret, select, or produce graphs well. From a semiotic perspective, it is important that the graphs gain a symbol function: in the eyes of students they have to represent statistical objects, such as for example the frequency distribution of a data set. This process was analyzed under the heading of symbolizing.

*Computer tools*. Without computer programs analyzing data is laborious. Because most statistical programs are suitable for analyzing data, but not for *learning* to analyze data, specially designed educational software, the Statistical Minitools (Cobb et al., 1997), has been used in the present research. These Minitools have been designed for the Nashville research for students of about 12 years old, and have been translated and revised for the Dutch research presented here. In the first Minitool

---

1. Granted by the Netherlands Organization for Scientific Research, project number 575-36-003B.

(Figure 6.1), each data value is represented by a horizontal value bar. Its length is relative to its value. In the second Minitool, the end points of the bars have been collapsed down onto the axis. Thus we get a dot plot in which a normally distributed data set looks like a bell curve (Figure 6.2). In the third Minitool, students can structure multivariate data sets in scatterplots in different ways, but this tool has not been used in the present research.

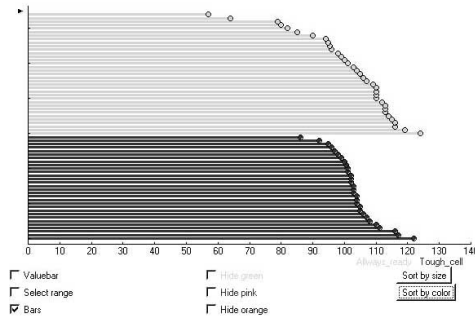

Figure 6.1 Minitool 1. The data set is of life spans in hours of two battery brands, here sorted by size and by brand (color).

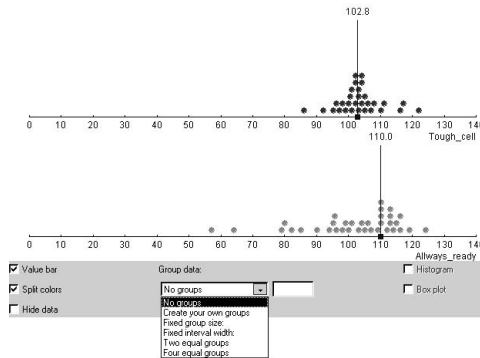

Figure 6.2 Minitool 2. The same battery data set in a dot plot

## 6.2 Background and research questions

One of the principles of the research was that learning mathematics should be a meaningful activity. The theory of Realistic Mathematics Education (RME) offers tenets on mathematical learning and design heuristics. Instead of offering ready-made mathematics that can be applied later, I aimed for a process of guided reinvention.

The research was prepared in several steps. After a survey of relevant research literature, the results of the Nashville research were summarized. Also, a historical study into the development of statistical concepts and graphs was carried out to gain ideas

for instruction. Exploratory interviews have been conducted with 26 Dutch seventh-grade students to identify the entrance level for instruction. The combination of these findings formed the basis for a so-called didactical phenomenology (Freudenthal, 1983) on which the first learning trajectory was based.

Statistical data analysis is used for the description and prediction of group characteristics of data, not of individual cases. It turns out that students have difficulties in conceiving of aggregate characteristics of a data set as a whole. Instead, they mostly conceive of characteristics of individual cases. Furthermore, they perform badly when interpreting and selecting graphical representations in which individual cases are aggregated, for instance in a histogram or a box plots.

The core concept of statistics with which patterns in variable phenomena and group features of data sets can be modeled is *distribution*. The starting point of the Nashville research was that, with a notion of distribution, students would be able to describe and predict such group features. For this age group, we can think of a distribution as the distribution of data over a variable. Because a formal definition of for instance the normal distribution is too difficult for seventh graders, the Nashville team focused on the *shape* of distributions in the design of the learning trajectory.

In the Nashville research it proved possible to let students reason about group features of distributions, for instance by reasoning about shape (“the hill is more to the left,” which meant that the majority of the data was lower). Nevertheless there were also new questions, in particular about the role of the mean and sampling, and about the symbolizing process. Based on the literature study and the Nashville research the following two research questions have been formulated for the present Dutch research:

- 1 *How can students with little statistical background develop a notion of distribution?*
- 2 *How does the process of symbolizing evolve when students learn to reason about distribution?*

### 6.3 Methodology

The design research presented here consisted of five cycles of three phases, four in grade 7 and one in grade 8 (students were 12 to 14 years old). In the first phase, a teaching experiment was prepared. Based on available knowledge and experience, a hypothetical learning trajectory was formulated, including end goals, instructional activities, and expectations about students’ learning processes. In the second phase, a teaching experiment was conducted. In the third phase, the learning process was analyzed. Several questions could be answered in the analysis, for instance: Did the expectations come true? Which revisions are necessary? What notions of spread do the students have in particular contexts? Based on a retrospective analysis, the hypo-

thetical learning trajectory was revised for the next cycle. Characteristic of design research is that the most viable route can be chosen at any time, even if the teaching experiment has not yet finished. In other words, there can be mini-cycles of analysis within the second phase of a design research cycle.

During the retrospective analyses in classes 1B (23 students, grade 7) and 2B (30 students, grade 8), I have formulated conjectures that have been tested on remaining episodes and other data sources. This process of generating and testing conjectures was then repeated several times using a method that resembles the constant comparative method of Glaser and Strauss (1967).

Several data sources have been collected to register students' learning process: audio and video recordings of students in the classroom, student work, tests and field notes, but also audio recordings of debriefings with assistants after lessons. An important part of the data corpus was a set of mini-interviews to find out what graphs and concepts meant for students. The mini-interviews were conducted in the classroom according to a set of formulated questions that had been discussed with the assistants. The length of these mini-interviews varied from about twenty seconds to four minutes. The audio and video recordings of classes have been transcribed. The transcriptions of class 1B have been entered into a computer program for protocol analysis (Erkens, 2001) and coded for activity, words and concepts. The purpose of this was to systematically analyze the transcripts, generate conjectures and easily retrieve all episodes about a particular instructional activity or concept to test conjectures. The transcriptions of class 2B were coded by the researcher and about one quarter was discussed with three assistants. There was a high rate of agreement among judges.

#### **6.4 Historical phenomenology**

To prepare the design of the hypothetical learning trajectory, a historical phenomenology (Freudenthal, 1983) has been carried into the development of key statistical concepts such as mean, median, sample, and distribution. The core question was which phenomena gave rise to the development of statistical concepts and how these concepts were used to organize phenomena. Based on these historical examples, hypotheses were formulated about the learning of these concepts. The first hypothesis was that estimation of large numbers is a suitable context for letting students use an implicit notion of mean in relation to a total estimated number. Another hypothesis was that students would use the midrange, the mean of the two extreme values, as a measure of center. I have also formulated hypotheses about learning the median, sample, distribution, and graphs. The hypotheses that could be tested have all but one been confirmed.

The historical analysis supported the design process in different ways. It turned out useful to distinguish between aspects of concepts such as mean and sample, and it helped to better look through the eyes of the students.

## 6.5 Exploratory interviews and a didactical phenomenology

The analysis of the exploratory interviews with 26 seventh graders showed that these students were reasonably fluent in calculating the arithmetic mean. They attributed several qualitative aspects to the notion of mean such as ‘the most’, ‘about’, ‘balance point’, ‘midrange’, ‘the middlemost’, ‘centre of gravity’, and ‘majority’. However, there seemed to be no good connection between those qualitative aspects of the mean and the arithmetic mean as an algorithm. It further turned out that two exemplary instructional activities of the Nashville research with Minitool 1 and 2 were also suitable for the Dutch students to support reasoning about distribution aspects.

Based on the literature study, the historical study and the exploratory interviews, an analysis was made of the notion of distribution in relation to other statistical key concepts. In line with the Nashville research, students were stimulated to describe how the data were distributed and to describe the shape of graphs in terms of group features. My expectation was that, if the notion of distribution were to become an object-like entity, students would be able to describe statistical features of it such as center, spread, and density, and skewness. The question, however, is how this reification process evolves. Existing theories about reification describe how a procedure is encapsulated into an object (e.g. Tall et al., 2000), but in the case of the notion of distribution it was not clear to me what the procedure would be. In my view, distribution was more like a composite unit than a concept with a procedural and structural side. Just as the number 10 can be both ten units and one unity, a data set can be seen as the collection of individual values but also as a unity with properties the elements of the collection do not have. The eighth-grade experiment (Section 9) provided new insights into this issue.

Inspired by the historical examples of the mean that was probably used to estimate large numbers, I decided to start the seventh-grade unit with estimation. The students were first asked to estimate the number of elephants in a picture. A similar estimation question was: How many seventh graders would you allow in a balloon if normally eight adults are allowed? Using such questions I expected to be able to discuss the concepts of mean and sample at an informal level.

The hypothetical learning trajectory, in a one-sentence summary, was that students would learn to reason about distribution aspects using increasingly sophisticated graphical representations and statistical notions. The means of supporting this process were the Minitools and the activities used in Nashville, but also newly developed instructional activities.

## 6.6 Designing a hypothetical learning trajectory for grade 7

In three cycles of design research, a hypothetical learning trajectory was developed that could be tested in the last teaching experiment in grade 7. Within certain contexts and in relation to value-bar graphs and dot plots, students learned to describe various aspects of data sets and to use these aspects in their reasoning: the mean, reli-

ability (of battery brands), outliers, more higher values (skewed distribution). They described the spread of the data in terms of ‘spread out’ and ‘close together’. To stimulate students to focus on group features of data sets, I asked them to invent graphs that matched particular group features, such as an unreliable battery brand with a long life span.

One of the conclusions of the retrospective analyses was that students were inclined to group distributions into three groups of low, ‘average’, and high values. Moreover, it turned out to be useful to let students invent their own graphs, let them compare those graphs, and ask what-if-questions about hypothetical situations.

In class 1E, a class discussion emerged during the eleventh lesson about two student graphs and the bump that was seen in one of them (Figure 6.3, right of item 9). Despite earlier attempts, this was the first time that the shape of a distribution became a topic of discussion. Students from this class used the notion of bump to solve other problems in subsequent lessons. Because this class came closest to the end goal of reasoning about the shape of distribution, I analyzed the symbolizing process in this class in more detail (Section 8). I decided to dismiss the end goals of distribution as an object for the last teaching experiment in grade 7, because I had become convinced that this end goal was too ambitious for the seventh-grade class having 12 lessons. Instead, it seemed wiser to focus on how data were distributed and on the notions of spread and sample.

In different cycles of design research, the hypothetical learning trajectory was developed and patterns in students’ learning process and the means of support were detected. The variations between the classroom teaching experiments show how small differences in the activities can lead to considerable differences in the learning outcome.

## 6.7 Answer to the first research question

As mentioned before, the one-sentence summary of the hypothetical learning trajectory was to challenge students to reason about distribution aspects with increasingly sophisticated notions and diagrams. In the hypothetical learning trajectory for 1B, I initially focused on center and spread as the most important distribution aspects and then factored everything together by discussing samples and by making shape a topic of discussion. Based on the experiences in all teaching experiments in grade 7, this section provides a reconstruction of the hypothetical learning trajectory and thus gives an answer to the first research question of *how students with little statistical background can develop a notion of distribution*. I claim that students can learn to reason about distribution if a hypothetical learning trajectory similar to this reconstruction is used, provided it is adjusted to local contingencies. It is likely, for instance, that more lessons are needed than I used, to compensate for the learning effect of the mini-interviews. The following nine items form the key activities of the hypothetical learning trajectory. Items 1, 3, and 6 (on the left in Figure 6.3) focus on

center, whereas items 2, 4, and 5 focus on other distribution aspects; 7, 8, and 9 draw the different aspects together. The following assertions have to be taken as anticipatory conjectures that can be tested and revised in educational practice (cf. RAC, 1996).

*1. Estimate a large number of objects in a picture.* When estimating the size of a herd of elephants for instance, students need to find a way to use part of the picture to find the total number. One of the possible strategies is to make a grid and count the elephants in what students called an ‘average box’, which is the box in the grid representing the other boxes such that the total is accurate. In discussing what an average box is, students learn to look at how values are distributed. The average box is also a sample that is chosen because its size helps to say something about the total. The issue of representativeness can thus be dealt with in an intuitively clear manner. It is possible that students use a midrange strategy of averaging the fullest and emptiest box in the grid. Skewed distributions in other grids can then be used to challenge the midrange as a measure of center and focus students’ attention on how values are distributed in relation to the center.

*2. Compare different distribution aspects in a value-bar graph.* To avoid the so-called mean distractor effect, distribution aspects other than the mean have to be addressed. The two battery data sets were chosen based on similar means, but different distributions: one is normal and one skewed. In this way, students are stimulated to describe other features of the data sets than the mean. They are likely to reason about extreme values, values that are close together, and the reliability of the brands. In other words, they start to reason about spread issues.

*3. Explain what an average box is in a value-bar graph (reinvention of a compensation strategy for visually estimating the mean).* The first estimation activity, together with students’ experience with value-bar graphs, forms the basis for visually estimating means. In this way, students can further develop qualitative and conceptual aspects of the mean, such as intermediacy, balancing and compensation, and representativeness.

*4. Invent data according to aggregate features and coordination of center and spread in a meaningful context.* Inventing data according to aggregate features of battery brands, or anything else, can stimulate students to develop an aggregate view of data. By answering questions such as what an unreliable brand with a long life span looks like, students learn to coordinate center and spread aspects. Students probably use predicates such as ‘reliable’ in different ways. Some may find brand D more reliable because its range is smaller, but others may find brand K more reliable because it has more of the same value. This reflects two different views on spread.

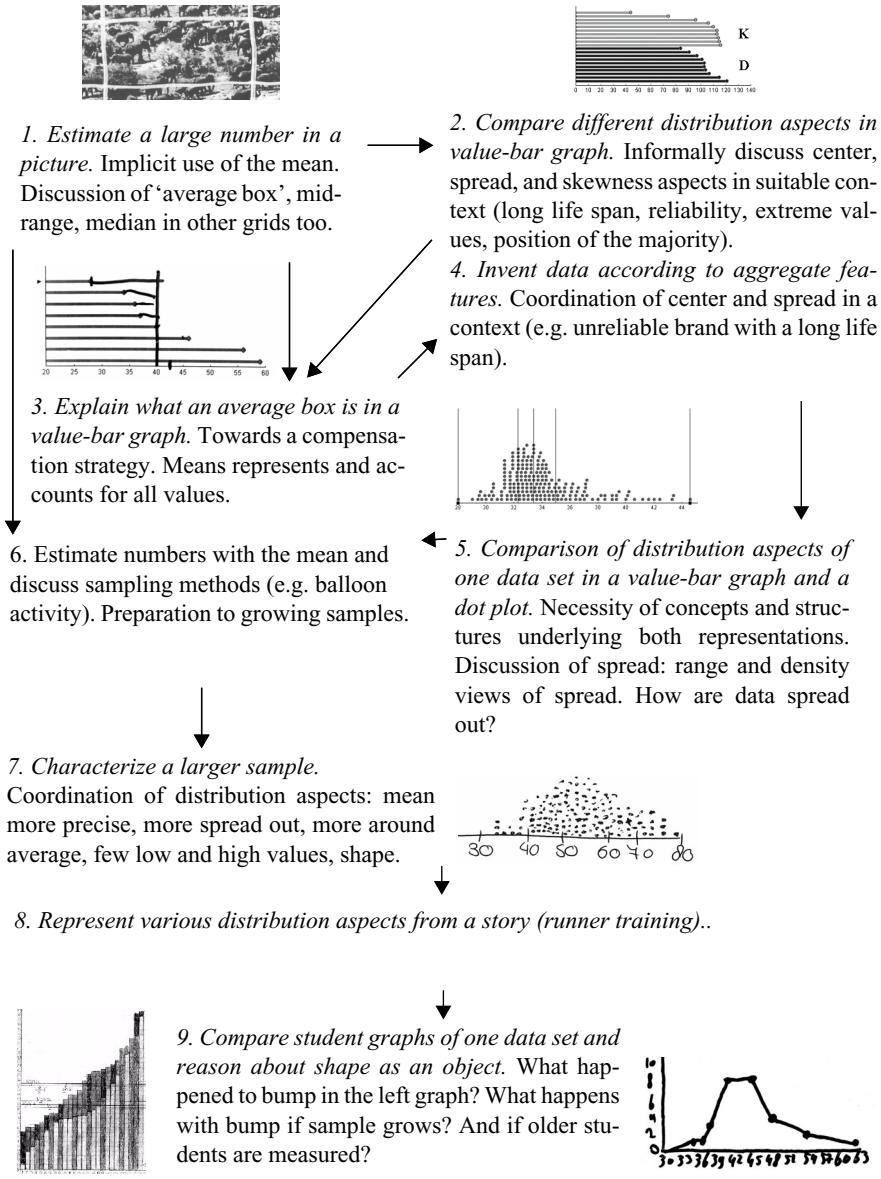

Figure 6.3 Schematic overview of the reconstructed hypothetical learning trajectory based on the experiences in grade 7

The first is a *range view* on spread and the second is a local view on spread that I characterize as a *density view*. In student language, this density view can be expressed as follows, in this example related to a dot plot organized into four equal groups: “Here the dots are spread out, but there they are close together.” Students also combine the two views, for example when they explain how they examine a data set: “I first look at the highest and lowest, and then in between.” It is probably necessary to introduce the notion of range to avoid situations in which students use the term ‘spread’ for the range only. Students are not likely to view spread as dispersion from a measure of center in such contexts as I have chosen, but this could be different in a context of repeated measurements of a ‘true value’.

5. Compare spread of data sets in a value-bar graph and a dot plot. Describe how data are spread out with respect to organized dot plots. When describing how values or dots are spread out, students probably describe how the data values are distributed. This means that if the instructional design and teaching stimulate students to describe how data are spread out, they can also develop a sense of how data are distributed in relation to the meaning of the context. For instance, “the majority is more to the left” or “in the beginning the dots are less spread out.” Students gradually develop a language in which they can express how data points are distributed, for example in reference to brand K: “In the beginning the steps are large and at the end they are small.” The grouping options in Minitool 2 help students to express differences in density, especially in relation to four equal groups and fixed group sizes (for example in a problem situation such as the speed sign).

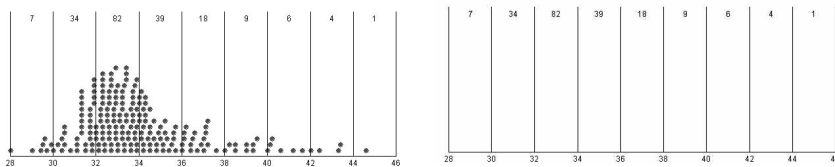

Figure 6.4 Dot plot structured into equal intervals and with ‘hide data’

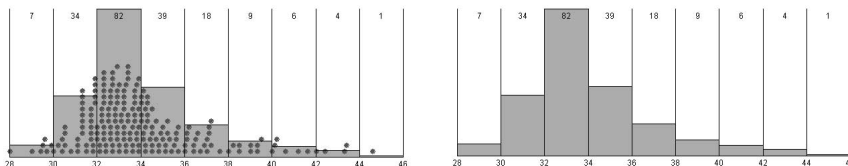

Figure 6.5 The histogram overlay that was made available in the revised version of Minitool 2

After a few lessons with Minitool 2, students may be able to explain features such as the following: if the vertical lines of four equal groups or fixed group size are close together, the dots are bunched up or close together, even when data are hidden. The implication is that they learn to see how the dots are distributed through the abstract diagrams that stem from grouping options in several ways and from hiding the data. For instance, grouping data into four (roughly) equal groups may support the understanding of box plots and grouping into equal intervals may support the understanding of histogram (Figures 6.4 and 6.5).

*6. Estimate numbers using a notion of average, and discuss sampling methods.* The balloon activity is a variant of the elephant estimation problem, but the sampling issue is more complex. In the elephant task, the population is the whole herd visible in the picture, but in the balloon context, students need to use their contextual knowledge or simple sampling techniques to find out about students' and adults' weights. Again they may use average values as representative values and tools in their reasoning. The balloon activity forms the starting point of the growing samples activity in which students' initial guesses of weight averages are challenged. One possible disadvantage of the balloon activity is that it may reinforce the mean distractor effect.

*7. Characterize a larger sample.* After focusing on center and spread, the hypothetical learning trajectory aims at reasoning about shape as standing for the distribution of a data set as a whole. During the activity of growing samples, students predict the shapes of large samples (or even populations). In comparing their predictions with diagrams of real data sets, students are expected to reason about aggregate features of the samples and about shape. In Section 9, I elaborate on the growing samples activity and the importance of distinguishing between 'spiky' shapes of real data and idealized shapes with which experts model data.

*8. Represent various distribution aspects from a story.* The following example gives an impression of the extent to which seventh graders learned to reason about distribution. In the second assessment task of 1B, students had to draw diagrams that matched with a story on running trainings. From this item I concluded that most students were well able to symbolize case-oriented and many aggregate features of the story into the diagrams. Students can describe how data points are spread out or distributed, but reasoning about shape is probably difficult to accomplish in only twelve lessons.

*9. Compare student graphs of one data set and reason about shape as an object.* If students make various graphs of one data set they know well, they are likely to

understand that these graphs are different representations of the same structure. Using what-if questions about hypothetical situations, teachers can support students in reasoning about shapes as objects. However, such reasoning is probably challenging to accomplish in grade 7.

## 6.8 Answer to the second research question

I used semiotics for analyzing the symbolizing process when students learned to reason about distribution. Peirce's semiotic theory turned out to be the most viable for this purpose. Compared to the theory of chains of signification, for instance, one major advantage of Peirce's theory of signs is non-linearity. Before summarizing an answer to the second research question of how the symbolizing process evolved, I briefly define the semiotic notions that are most important to the analysis.

In Peirce's theory, a sign stands in a triadic relation to an object and an interpretant. The interpretant is the response of an interpreter to the sign. Signs can have different functions depending on how they are interpreted. A sign is a symbol if its relation to its object and its interpretant is formed by habit or rule (and not by similarity for instance). A *diagram* is an icon representing relations (most statistical graphs are therefore used as diagrams). *Diagrammatic reasoning* involves three steps: constructing a diagram, experimenting with it, and reflecting upon the results. Anything that is thought or talked about is an object in Peirce's theory, and this object is mediated by a sign. From an educational point of view, it is therefore important that the topics of discussion are clear. The process of describing qualities of those topics or objects can be called *predication*. Next, *hypostatic abstraction* is one of the forms of abstraction that Peirce distinguished: a predicate becomes an object in itself that can have characteristics. This is linguistically reflected in the transition from a predicate (e.g. most, lying out) to a noun (majority, outlier). Symbolizing, within this theory, involves making a sign that is interpreted as a symbol, but generally also requires forming the object for which it stands: the symbol of a hill has to stand for an object, which students in general still have to develop (a notion of distribution). The notion of diagrammatic reasoning in combination with that of hypostatic abstraction offers a framework for analyzing the symbolizing process: symbolizing involves both the step of making a diagram (diagrammatization) and forming an abstract object such as distribution (e.g. by hypostatic abstraction). One advantage of using a differentiated notion of sign is that we can analyze students' difficulties with graphs in differentiated ways: we cannot simply say that, for instance, histograms are difficult. Semiotically, interpreting elements of a sign such as reading off values from a plot is not so difficult, but to interpret the plot as a diagram standing for relations between data or even as a symbol standing for a frequency distribution requires much more conceptual understanding.

The hypothetical learning trajectory was to challenge students to reason about distribution aspects with increasingly sophisticated notions and diagrams, which can

also be conceived semiotically as progressive diagrammatic reasoning about distribution aspects. In the remainder of this section, I highlight the most important ingredients of the symbolizing process when students learned to reason about distribution.

*Predication is a prerequisite for hypostatic abstraction.* In all experiments, the estimation, battery, speed sign, and other activities were used to foster a process of predication: describing aggregate features of diagrams and what they represent. The activities aided students in describing features of the data sets with adjectives such as ‘average’, ‘most’, ‘reliable’, ‘spread out’, and ‘low and high values’ with respect to signs such as value-bar graphs and dot plots. The objects students talked about were mostly the bars and dots that stood for data values. The most common way of grouping data was into low, average, and high values. The instructional activities also offered opportunities for hypostatic abstraction, for instance of the average, majority, reliability, spread, and outliers. These notions have thus become distribution aspects with an object character, but these objects were still under development (‘immediate objects’, in Peirce’s terms, not ‘final objects’).

*Coordinating the steps of diagrammatic reasoning and diagrammatization according to aggregate predicates that are mean or spread related.* One useful experimentation experience was using the vertical movable value tool for estimating means in value-bar graphs (as could be done in Figure 6.6) and reflecting upon why this compensation strategy worked. Furthermore, student experimentation with the data sets in Minitool 1 and reflection on the features of the battery brands form the basis for diagrammatization of aggregate features such as “brand A has a long life span but is unreliable.” In this way, students learn to think in center and spread-related terms with respect to diagrams, and to extend their case-oriented view with an aggregate view of data.

*Diagrammatic reasoning about shape.* According to the hypothetical learning trajectory, the shape of a distribution had to become an object with aggregate properties. These properties are to represent features of the distributions, which in turn represent properties of the problem situation. To analyze this process and answer the second research question, I focused on the students’ reasoning with bumps in class 1E.

The semiotic analysis showed that *diagrammatization* can involve multiple actions. Mike, for example, informally grouped the weight data values, used dots at certain positions to signify these groups and their frequencies, and connected the dots to one shape (Figure 6.3 right of item 9; it looks like a frequency polygon, but the step size is irregular). Each of these actions has a history, either in the teaching experiment (e.g., grouping data and using dots) or in mathematics lessons (e.g., line graph).

During the *reflection* on the diagrams, the teacher introduced the term ‘bump’ to make this shape the topic of discussion. Students perhaps first interpreted the bump as an icon (a visual image of a bump), but the analysis shows that the meaning of the bump notion was not just iconic, and even changed from the eleventh to the thirteenth lesson, for several students at least. In the eleventh lesson, students used the bump notion to refer to a group of values close together in the middle part of the graphs (‘majority’). The interesting thing is that the same data set looked so different in various student graphs. By relating the bump in Mike’s graph to Emily’s graph (Figure 6.3, left of item 9), the teacher stimulated students to specify what the object was which looked like a bump in Mike’s graph and a straight line in Emily’s. This object, a group of values that were close together, can be seen as a hypostatic abstraction. We can also speak of it as the common conceptual structure underlying aspects of both graphs. To conceive of such a structure, however, students need to have a history of reasoning with such plots and similar phenomena (see previous section).

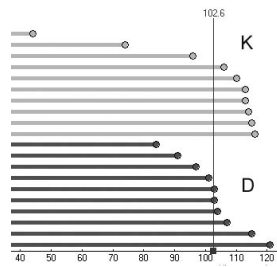

Figure 6.6 Reasoning with the ‘bump’ in a value-bar graph using the vertical value tool (“The bump of brand K is higher.”)

In the twelfth lesson, several students used the term ‘bump’ for a group of data even when there was no visual bump, for instance when they referred to the vertical straight part in value-bar graphs as a bump (Figure 6.6). This implies that the bump was not just a visual characteristic, but had become a conceptual object and even a reasoning tool, for instance for arguing which battery brand was better.

In the thirteenth lesson, several students referred to ‘bump’ as the whole shape, whereas before they had only referred to the area surrounding the peak of the hill shape, which for them represented a group of values being close together (‘majority’). The development of the bump as an object was probably stimulated by questions about hypothetical situations in which students needed the bump as an object. When I asked about the shape of a graph from a much larger sample, one student argued that it would grow wider if the sample were bigger because there would be more extreme values. Other students reasoned that the bump would stay the same because there would also be more ‘average’ values. This suggests that those students

had an image of the distribution independent of the sample size. Students also answered the question of what would happen if students of a higher grade were measured. One student said that the bump would be shifted to the right. In that sense, the bump had become an object encapsulating the data set as a whole. Several students were able to relate aspects of that shape to distribution aspects such as average, majority, groups of values, and several acknowledged the stability of the shape across sample size. They even hypothesized on the shape of a large sample, which means they modeled hypothetical situations with a notion of distribution, which was indeed the end goal of the hypothetical learning trajectory.

The analysis presented here can be taken as a paradigmatic example of explaining symbolizing as embedded in a process of diagrammatic reasoning in which opportunities for hypostatic abstraction occur. I anticipate that modeling in mathematics and science education can be analyzed as diagrammatic reasoning as well.

### **6.9 Answer to the integrated research question**

Because the hypothetical learning trajectory could also be summarized as progressive diagrammatic reasoning about distribution aspects in relation to growing samples, the first and second research questions became strongly related. I therefore formulated the following integrated research question for the teaching experiment in grade 8:

*How can students with little statistical background develop a notion of distribution by diagrammatic reasoning about growing samples?*

The eighth-grade teaching experiment was organized around the recurring activity of growing samples to test the conjecture that students could develop a notion of distribution by reasoning about larger and larger samples. As before, I do not want to suggest that the activity of discussing growing samples is the best way to let students develop notions of distribution and sampling coherently. The purpose is to understand how such an activity can support students' reasoning. Again, I cast the reconstructed hypothetical learning trajectory in terms of anticipatory conjectures that can be tested and revised in practice. The focus here is on the lessons in which activities were carried out related to discussing growing samples.

*Diagrammatization according to group characteristics of larger samples.* Because variability is the most fundamental concept in statistics, it is important to choose contexts in which students are likely to acknowledge variability: without such understanding there is no need for taking a sample, computing a mean, measuring spread, or looking at the shape of a distribution. Industrial contexts such as the life span of batteries appear to be unsuitable starting points. The experience in grade 8

demonstrates that much can be revealed about students' intuitions of statistical notions when they design their own methods of sampling. Students presumably choose sample sizes that are too small or want to test the whole population. To challenge those views and to promote attention for aggregate features of data sets, teachers can ask what a larger sample with a specific aggregate feature might look like. This promotes diagrammatization according to group characteristics of data sets but also mental experimentation (a what-if attitude) and reflection on aggregate features and sample size. I asked, for instance, what a larger sample of a good and a bad battery brand would look like but, as mentioned earlier, I would not choose such an industrial context again.

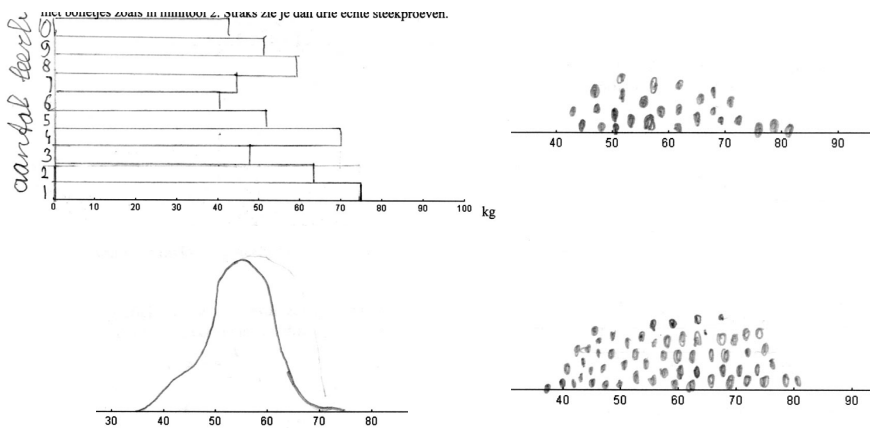

Figure 6.7 Samples of different sizes as predicted by one eighth grader. Clockwise from top left, the samples sizes are: 10 (value bar graph as in Minitool 1), 27, 67 (dot plots as in Minitool 2), and the whole province (he called this a 'bell shape').

*Extend the samples to populations and create the need for drawing continuous shapes.* In short cycles of growing samples of a familiar context, for instance weight or a less sensitive context, students may be asked to predict diagrams of samples with a specific size and compare those with real samples of that size (Figure 6.7). In this way, reflection can be stimulated about the diagrams and conceptual aspects of the samples in terms of center, spread, and shape. For larger samples students can use dot plots or continuous sketches and predict the shape of the population distribution. Hill, bell curve, pyramid, and semicircle are among the many possibilities. It depends on the context whether students will acknowledge the skewness of unimodal distributions. In the weight context, students probably do not expect a skewed shape, but skewness can be made a topic of discussion by discussing left and right limits in relation to the mean.

When students reflect on comparing predicted diagrams and real data sets, it is crucial that distribution aspects become clear topics of discussion, so that objects can be formed that can be refined during the remainder of the instructional sequence. In particular, think of the following distribution aspects: average, low and high values, outliers, range, spread, and shape. Linguistically, transitions should be stimulated from predicates such as ‘most’, ‘lying out’, and ‘spread out’ to nouns such as ‘majority’, ‘outlier’, and ‘spread’. The formed hypostatic abstractions can be predicated again: for example, “the majority lies between 23 and 35,” “there is an outlier at 107,” and “the spread is large.” Drawing on their context knowledge, students can use these statistical objects as reasoning tools about shapes. However, care should be taken that students do not just mimic their teachers in using particular nouns.

The challenge is to strike the balance between providing space for exploration, participation, and reinvention on the one hand, and guidance towards culturally accepted and precisely defined notions on the other. It can be demanding for teachers to see the potential of students’ ideas and supporting students in the next step. At some point, it will be necessary to discuss conventional notions such as range, median, mode, and outliers to avoid confusion between range and spread; between mean, midrange, and median; and between extreme values and outliers. This is preferably done after students have experienced the need for such distinctions themselves.

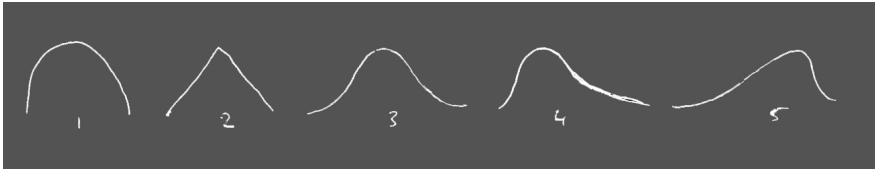

Figure 6.8 Shapes discussed in grade 8

*Discussion of shapes.* To address the distribution aspect of skewness, the different shapes students propose themselves probably need to be expanded with skewed shapes. In grade 8, students discussed the shapes of Figure 6.8 and used statistical notions such as mean and outlier to explain why certain shapes could not represent a weight distribution. During the diagrammatic reasoning about this, the statistical notions of mean and ‘outlier’ were used as reasoning tools. Students also implicitly reasoned about frequency and density in this phase. To make skewness a topic of discussion as well, I introduced two skewed shapes. Students finally learned to describe shapes and distributions as being uniform, normal, skewed to the left or to the right. This means that shape had become an object that they could reason about with appropriate names.

The next step, which I overlooked in the eighth-grade teaching experiment, is to sup-

port students in recognizing shapes in dot plots or other plots in which variation around the smooth curve makes it difficult to perceive the signal in the noise. It is likely that students do not see the same shapes as experts, because they need to develop conceptual structures to perceive those or model the situation with a well-known distribution such as the normal distribution. They also need to experience when it is legitimate to reduce the complexity of a data set with a model (the signal) that includes variation (noise) around it. This implies that idealized shapes should also be made topics of discussion as well as deviations from such shapes, for instance by asking what different data sets (with the same distribution) have in common.

It seems wise to use both case-value plots (such as dot plots) and aggregate plots (such as continuous shapes). Consider this example. Most students in the final interviews could indicate where the mode and mean were in a sketch of a right-skewed distribution, but mistook the median for the midrange (Figure 6.9). By mentally going back to the two-equal-groups option in Minitool 2, several students could correct themselves and indicate where about the median would be in the continuous sketch. In this way, the measures of center were treated as characteristics of a distribution and not just as outcomes of computations performed on individual data values.

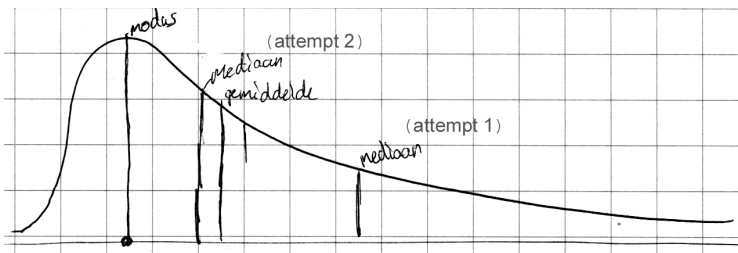

Figure 6.9 Sketch of a skewed distribution in which students indicated the position of the mode (modus), median (mediaan), and mean (gemiddelde). They initially (attempt 1) mistook the median for the midrange.

Having sketched the most important steps in the reconstructed hypothetical learning trajectory, I now discuss students' notions of distribution. One of the end goals of the hypothetical learning trajectory was that distribution would become an object-like entity. I initially considered a distribution more like a composite unit than an object with a procedural and structural side and wondered what the procedural side of a distribution would be (Section 5). In describing what a distribution was, students often used the term 'spread out': distribution is how the dots are spread out over the graph. From the way students talked about distribution, in particular during the final interviews, I inferred that they imagined the process of distributing dots over the var-

iable as if growing a sample in a dot plot. I conjecture that such a process view of distribution could well be the procedural side of the concept, but I realize that the focus on growing samples has also fostered this view of distribution.

The analyses in Sections 8 and 9 show that the reification process of distribution is in fact a complex process that involves many steps of hypostatic abstractions (cf. Sfard, 2000). Distribution is a multifaceted notion, the understanding of which requires understanding key aspects such as center, spread, density, and skewness. There seems to be a reflexive relationship between the development of such characteristics of a distribution and the notion of distribution as an object or a shape: by reasoning about the occurrence of low, average, and high values, students expect a particular shape, and by reasoning about shape, students develop the meaning of distribution aspects such as mean, spread, density, and skewness.

The question of whether distribution had indeed become an object for the majority of the students cannot be answered without specifying what we mean by distribution and by object. The research has in fact yielded different levels of understanding distribution of which I mention a few.

- 1 Before instruction, students probably know what is typical and what is not in specific contexts, and that typical values occur more often than exceptional values. This forms the basis for students' reasoning about distribution in natural contexts. However, students mostly lack the language in which they can express such intuitions.
- 2 The activities in the beginning of the teaching experiments support students in describing various distribution aspects in informal and context-bound ways, such as the reliability of a battery brand in relation to diagrams (predication). Predicates such as 'most' and 'lying out' can become hypostatized as 'majority' and 'outlier', though the meaning of such terms is still under development.
- 3 Students then learn and use statistical terms for such aspects as range, spread, median, distribution shapes, and skewness in relation to various diagrams.
- 4 After five lessons, most students in grade 8 were able to express that there were few low and high values and many around average, which could be seen from the relative height in continuous shapes.
- 5 However, it appears to be much harder to recognize ideal shapes (as signals) within the noise of a 'real' data set as represented in a dot plot. Students reasoned *about* shapes but not *with* shapes as reasoning tools to solve other statistical problems. Moreover, they found it hard to predict the shape of data sets of hypothetical situations such as train delays.
- 6 Furthermore, there seems to be a difference in viewing a distribution as a shape that emerges from growing a sample, the presumed procedural side of the concept, and distribution as a statistical object with characteristics such as range,

spread, mean, median, and mode. In the latter case, shape is an object that can be mentally manipulated and that can be used to predict and model new situations. Students conceiving a distribution in the former way need not understand it in the latter way.

Though students in the teaching experiments did not show understanding of all those levels, it is likely that their diagrammatic reasoning experience forms a fruitful intuitive basis for the more technical applications of the normal distribution they will encounter in grades 10 to 12. Because symbolizing and computer tools formed the central topics of the research, I discuss these separately.

### 6.10 Symbolizing

In this section, I discuss the advantages of using semiotics for analyzing students' symbolizing process, and in particular of using Peirce's semiotics as opposed to chains of signification. By framing episodes of student learning as examples of more general issues such as diagrammatic reasoning or hypostatic abstraction, the results can be generalized and the insights can be applied in new situations. For example, insights into students' diagrammatic reasoning can be linked with insights into students' ways of modeling in mathematics and science education. In this way, the present study gains theoretical validity and contributes to theory development. Apart from this issue of generality, my experience is that the semiotic framework used provided insights that I had probably not gained without it and provided a vocabulary to express insights more precisely than without those notions.

Peirce's triadic sign notion better suits the purpose of analyzing such non-linear processes as learning statistical reasoning than the dyadic sign of Saussure or Lacan. What makes Peirce's notion of sign non-linear is that the interpretant can be the reaction to multiple signs and that it can be the production of multiple new signs. Several researchers have used the notion of chain of signification for analyzing processes of symbolizing. This notion is too limited for analyzing more complex learning processes, for example, if they compare signs. Instead, I use the notions of diagrammatic reasoning, predication, and hypostatic abstraction to analyze student learning. The adjective 'progressive' was added to diagrammatic reasoning to stress that it should lead to, in this case, reasoning about distribution aspects with increasingly sophisticated notions and signs. Note that it is possible to describe chain-like signification processes with the Peircean notion, because the interpretant can be a new, more complex sign, the interpretant of which can again be a new, more sophisticated sign, and so on. I therefore regard Peirce's theory as superseding the theory of chains of signification.

Another advantage is that the notion of symbolizing can be embedded in a superseding framework of diagrammatic reasoning. Symbolizing is literally making a sym-

bol, and this includes both making the sign, for instance by diagrammatization, and forming the abstract object it represents (e.g. by hypostatic abstraction).

One feature of Peirce's semiotics that could be seen as a limitation is its lack of grounding in a psychological theory. Hence, researchers have combined semiotic and psychological or cultural-historical perspectives. One further research challenge I see is to develop a semiotics for IT applications. Semiotics has been developed for static signs, but signs in IT tools can be dynamic and interactive: if an interpreter dynamically interacts with an IT sign, how should the interpretant be defined? The interpreter's response is tied to the variety of rules of the IT tool that learners need not be aware of. One way to investigate this issue is to unravel the relationship between semiotics and the instrumental approach, which theorizes on how artefacts such as IT tools become instruments for solving mathematical problems in student hands (Drijvers, 2003).

### **6.11 Computer tools**

What can we learn from the experiences with the educational statistics software? In this section, I tentatively discuss a few affordances and constraints of educational software such as the Minitools and formulate hypotheses about different types of educational statistics software that have been developed for middle school students. One attractive feature of the Minitools is that it hardly takes any time to learn the technical aspects of the tools, unlike with computer algebra systems (Drijvers, 2003). However, there are few opportunities for exploring different representations, which I view as a constraint. Throughout the research I have looked for ways to let students make their own graphs and compare different representations of the same data set. When students made their own visual representations, these were generally very similar to the Minitools representations. This implies that software can heavily influence the way in which students make diagrams of situations. It is striking that many students made vertical bar graphs, though Minitool 1 only offers horizontal bars. This can be interpreted in two ways: the first is that the applet in its present form is too restrictive; the second is that students were not bound to the representation they had used. I assume the students in our study could have benefitted from using a more expressive tool (in the sense of Doerr & Zangor, 2000).

How can computer tools support diagrammatic reasoning? Computer software such as the Minitools appears most useful for experimentation with diagrams. For example, Minitool 1 with its value tool supported a visual compensation strategy in the present study (but not in the Nashville research). The experimentation experience with particular types of diagrams forms the basis for reflection. In supporting diagrammatic reasoning, computer tools should in our view also offer user-friendly options for diagrammatization.

The three Minitools form a series of small applications (or applets) that are designed for a particular HLT. I characterize such series as route-type software (Bakker,

2002). There are also larger applications such as Fathom, Tabletop, Tinkerplots, and VU-Stat that are not tied to specific HLTs, but that offer a landscape of possibilities for analyzing data. I call this landscape-type software in analogy to Fosnot and Dolk's (2001) notion of the landscape of learning. On the basis of our experience with the Minitools and Tinkerplots (Konold & Miller, 2004) I have formulated the following hypotheses, which can be generalized to route-type and landscape-type software.

- 1 Small applications such as the Minitools are useful for teaching specific issues, such as visually estimating means or preparing the introductions to histograms or box plots if there is no or little time to learn the software. However, there is a risk of a narrow path offering little exploration space for genuine data analysis.
- 2 It is easier for teachers to guide students in using simple tools and to discuss their reasoning with the tools because of the limited variety. Conversely, if students use a larger application in which they can make many different plots such as in Tinkerplots, it is more demanding for teachers to guide their students.
- 3 When using larger applications, students will spend more time finding a good representation of the data and on doing genuine data analysis, but perhaps learn less about specific topics that smaller applications can draw the attention to.
- 4 When using larger applications such as Tinkerplots, students need much time to learn specific features of the software and will not understand many of the plots they produce. Much reflection time is likely to be spent on the meaning of unconventional plots. Hence, students' meta-representational skills might improve, but their knowledge about conventional plots could deteriorate when using large applications.

It might be sensible to start with simple tools if students are young and inexperienced in analyzing data, and use larger applications for students who already have some statistical understanding and skills in reasoning with various plots. I assume that the students in our study could well have coped with a larger application such as Tinkerplots. Moreover, Tinkerplots offers the option to gray out options so that smaller environments such as value-bar graphs or dot plots with limited grouping options can be presented to students.

The question arises of what criteria there are for selecting a computer tool. I suggest two. First, is the tool likely to become meaningful to students? Second, can teachers guide students in learning to reason with this tool? Whichever tool is chosen, the instructional activities, assessment, and the way of teaching should be in tune with the tool, and vice versa.

## References

- Bakker, A. (2004). *Design research in statistics education: On symbolizing and computer tools*. Utrecht, the Netherlands: CD-β Press.  
On line: <http://www.library.uu.nl/digiarchief/dip/diss/2004-0513-153943/inhoud.htm>
- Bakker, A. (2002). Route-type and landscape-type software for learning statistical data analysis. In B. Phillips (Ed.), *Proceedings of the Sixth International Conference of Teaching Statistics [CD-ROM]*. Voorburg, the Netherlands: International Statistical Institute.
- Cobb, P., Confrey, J., diSessa, A. A., Lehrer, R., & Schauble, L. (2003). Design experiments in educational research. *Educational Researcher*, 32, 9-13.
- Cobb, P., Gravemeijer, K. P. E., Bowers, J., & Doorman, M. (1997). *Statistical Minitools* [applets and applications]. Nashville & Utrecht: Vanderbilt University, TN & Freudenthal Institute, Utrecht University. See [www.wisweb.nl](http://www.wisweb.nl) or NCTM (2003), Navigations book for Data analysis, grades 6-8.
- Cobb, P., McClain, K., & Gravemeijer, K. P. E. (2003). Learning about statistical covariation. *Cognition and Instruction*, 21, 1-78.
- Doerr, H. M., & Zangor, R. (2000). Creating meaning for and with the graphing calculator. *Educational Studies in Mathematics*, 41, 143 - 163.
- Drijvers, P. (2003). *Learning algebra in a computer algebra environment: Design research on the understanding of the concept of parameter*. Utrecht, the Netherlands: CD-β Press.
- Erkens, G. (2001). *MEPA: Multiple Episode Protocol Analysis* (Version 4.6.2). Utrecht: Utrecht University.
- Fosnot, C. T., & Dolk, M. (2001). *Young mathematicians at work. Constructing number sense, addition, and subtraction*. Portsmouth, NH: Heinemann.
- Freudenthal, H. (1983). *Didactical phenomenology of mathematical structures*. Dordrecht, the Netherlands: Reidel.
- Glaser, B. G., & Strauss, A. L. (1967). *The discovery of grounded theory: Strategies for qualitative research*. Chicago: Aldine Publishing Company.
- Konold, C., & Miller, C. (2004). *Tinkerplots*. Data analysis software for middle school curricula. Emeryville, CA: Key Curriculum Press.
- RAC (Research Advisory Committee of NCTM) (1996). Justification and reform. *Journal for Research in Mathematics Education*, 27, 516-520.
- Simon, M. A. (1995). Reconstructing mathematics pedagogy from a constructivist perspective. *Journal for Research in Mathematics Education*, 26, 114-145.
- Sfard, A. (2000). Steering (dis)course between metaphors and rigor: Using focal analysis to investigate an emergence of mathematical objects. *Journal for Research in Mathematics Education*, 31, 296-327.
- Tall, D., Thomas, M., Davis, G., Gray, E., & Simpson, A. (2000). What is the object of the encapsulation of a process? *Journal of Mathematical Behavior*, 18, 223-241.
- Zawojewski, J. S., & Shaughnessy, J. M. (1999). Data and chance. In E. A. Silver & P. A. Kenney (Eds.), *Results from the seventh mathematics assessment of the National Assessment of Educational Progress* (pp. 235-268). Reston, VA: National Council of Teachers of Mathematics.

---

## 7 Learning algebra in a computer algebra environment

*Paul Drijvers*

### 7.1 Research questions

The project ‘Learning algebra in a computer algebra environment’<sup>1</sup> reported upon here is a case of research on the integration of information technology (IT) into education, and on its influence on the learning of mathematics in particular. In this study we focus on two issues that are relevant to mathematics education today: the learning of algebra and the integration of technology – and particularly of computer algebra – into it.

Algebra has always been an important topic in school mathematics curricula, and often is a stumbling-block to students. The difficulties of learning algebra include its formal and algorithmic character, the abstract level at which problems are addressed, the object character of algebraic expressions and formulas, and the compact algebraic language with its specific conventions and symbols. Because of these difficulties, students often do not perceive algebra as a natural and meaningful means for solving problems (Bednarz et al., 1996; Chick et al., 2001).

The integration of IT is one of the ways in which solutions for these problems of learning algebra are sought. IT use is expected to contribute to the visualization of concepts, and can free students from carrying out operations by hand, thus directing their attention towards concept development and problem-solving strategies. In this way, IT use might lighten the traditional algebra curriculum for them. In the meantime, the integration of technology raises questions concerning the goals of algebra education and the relevance of paper-and-pencil techniques, now that they can be left to a technological device. For algebraic skills, the use of a computer algebra system (CAS) is of particular interest, as it provides a complete repertoire of algebraic procedures and operations (Heid, 1988; O’Callaghan, 1998).

The issue of integrating computer algebra use into the learning of algebra brings us to the main research question of this study:

*How can the use of computer algebra promote the understanding of algebraic concepts and operations?*

This question needs further specification. As algebra as a whole is too big a topic to address in this study, we confine ourselves to the concept of parameter. Parameters may emerge quite naturally from concrete contexts, and may also be means of generalization and abstraction. Therefore, addressing the concept of parameter may stimulate students to enter the algebraic world of formulas, expressions and general

---

1. Granted by the Netherlands Organization for Scientific Research, project number 575-36-003E.

solutions. Also, the concept of parameter allows for revisiting the different roles of ‘ordinary’ variables that the students have met before. The use of parameters may improve the students’ insight into the meaning and structure of algebraic formulas and expressions (Bills, 2001; Furinghetti & Paola, 1994). Therefore, the general research question is specified in the first research subquestion:

1. *How can the use of computer algebra contribute to a higher level understanding of the concept of parameter?*

Previous research on the integration of computer algebra into mathematics education shows that the idea of technology carrying out the elementary operations, so that the students can concentrate on conceptual understanding, is too simplistic (Artigue, 1997b; Drijvers, 2000; Guin & Trouche, 1999; Lagrange, 2000; Trouche, 2000). The technical skills that the students need to carry out procedures in the CAS environment both require some conceptual understanding and affect that understanding. As a second focus of this study, therefore, we consider the intertwined development of techniques in the computer algebra environment and of mathematical understanding in terms of the students’ mental schemes. This instrumental approach to IT use – which concerns the instrumentation process of establishing the dual relation between conceptual understanding and techniques in the IT environment – is the topic of the second research subquestion:

2. *What is the relation between instrumented techniques in the computer algebra environment and mathematical concepts, as it is established during the instrumentation process?*

## 7.2 Theoretical framework

While phrasing the research question, we wondered what theoretical perspectives could help us to investigate these issues. A ready-to-use theoretical framework for the study of learning algebra in a computer algebra environment was not available. Therefore, we selected those theoretical elements from research on learning algebra and mathematics in general that seemed promising for application in and adaptation to the focus of this study. As a consequence, most of these elements were taken out of their usual scope and localized for the aim of this study. This eclectic approach to theory is called ‘theory-guided bricolage’ (Gravemeijer, 1994). The following elements were included in our theoretical framework.

- The domain-specific instruction theory of Realistic Mathematics Education  
Key elements in the domain-specific instruction theory of Realistic Mathematics Education (RME) are guided reinvention and progressive mathematization, horizontal and vertical mathematization, didactical phenomenology and emergent

modelling (Freudenthal, 1983; Gravemeijer, 1994; De Lange, 1987; Treffers, 1987a, 1987b). Guided reinvention, progressive mathematization and didactical phenomenology were supposed to be useful for developing a hypothetical learning trajectory for the concept of parameter, and for designing instructional activities. The issue of horizontal and vertical mathematization might clarify the relation between concrete problem situations and the abstract ‘microworld’ of the computer algebra environment, which tends to have a top-down character (Drijvers, 2000). The notion of emergent modelling was supposed to be useful for distinguishing levels of activity. As is shown in Fig. 7.1, Gravemeijer (1994, 1999) distinguishes four levels of mathematical activity. The idea of emergent modelling is that models, which initially refer to a concrete context that is meaningful to the students, gradually develop into general models for mathematical reasoning within a mathematical framework.

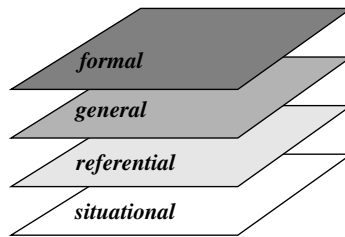

Figure 7.1 Four levels of mathematical activity (Gravemeijer, 1994, 1999)

- Level theories

The first research subquestion speaks of ‘a higher level understanding of the concept of parameter’. To make explicit what is meant by that, several perspectives were considered. First, Van Hiele’s level theory distinguishes between a ground level, a second level and a third level of insight (Van Hiele, 1973, 1986). This distinction might be useful for defining levels of understanding of the concept of parameter. A second approach to the levels involves the concepts of emergent models and levels of activity (see Fig. 7.1). In fact, in this study we aim at the transition from referential to general level of activity.

- Theories on symbol sense and symbolizing

The notion of symbol sense concerns the sense for algebraic entities in general and the insight into formulas in particular (Arcavi, 1994). In this study, we defined symbol sense as the insight into the meaning and the structure of algebraic expressions and formula. Working in a computer algebra environment with parametric formulas was supposed both to require this kind of symbol sense and to foster it.

How does one acquire symbol sense? Theories of symbolizing stress the parallel

development of symbols and meaning by means of a signification process (Gravemeijer et al., 2000). Because giving meaning to algebraic techniques, formulas and expressions as they appear in the computer algebra environment seemed to be an important aspect of the instrumentation process, a symbolization perspective was supposed to be relevant in this study.

- The process-object duality

The process-object duality concerns the idea that a mathematical concept can be considered both as a process and as an object. Often, students first experience the process aspect; on the basis of this they may develop the object aspect, which is a prerequisite for conceptual progress. This development is called reification (Sfard, 1991) or encapsulation (Dubinsky, 1991) and results in proceptual understanding (Tall & Thomas, 1991). These theoretical notions concern mathematics in general, but can also be applied specifically to the learning of algebra.

In this study we considered the reification of expressions and formulas, because perceiving formulas and expressions as objects is important for developing the concept of parameter. Furthermore, computer algebra use might affect the relation process-object. Reifying formulas and expressions involves overcoming the lack of closure obstacle, viz. the students' inability to see expressions and formulas as results if these contain operators; in  $a+b$  or  $x+3$  for example, the students would prefer to carry out the addition (Collis, 1975; Küchemann, 1981; Tall & Thomas, 1991). The reification of formulas and expressions does not imply the reification of function, which involves more aspects.

An important theoretical element in our study is the instrumental approach to IT use. We address that issue separately in Section 7.4.

### 7.3 Analysis of the concept of parameter

This study included a conceptual analysis of the concept of parameter.

We started this conceptual analysis with an investigation into its historical development. Essential in this development was the transition from syncopated to symbolic algebra that is characterized by the work of Diophantus and Viète (Boyer, 1968; Harper, 1987). Whereas Diophantus (ca. 250 A.D.) used literal symbols to denote unknown variables but not parameters, Viète (1540 - 1603) provided general, parametric solutions. He distinguished unknowns from parameters by using vowels and consonants. Apparently, he accepted expressions as solutions to general, parametric equations and thus considered them as objects. In our study, we aimed at this jump 'from Diophantus to Viète', or from the referential to the general level (Fig. 7.1). The time that this step took in history evinces its complexity.

The conceptual analysis of the notion of parameter led to the idea that a parametric formula or expression represents a second-order function. For example, the short arrow in Fig. 7.2 indicates that  $x \rightarrow a \cdot x + 5$  for a fixed value of the parameter  $a$  rep-

resents a – linear – function in  $x$ . As soon as the value of  $a$  changes, the long arrow in Fig. 7.2 indicates a second-order function, with the parameter as argument and linear expressions as function values (Bloedy-Vinner, 2001). As the main difficulties of the concept of parameter we identified this hierarchical relation with ordinary variables, represented in Fig. 7.2 and in the expression ‘variable constant’, and the distinction of the different roles of the parameter, which may change during the problem-solving process.

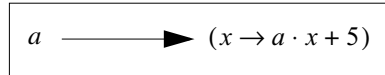

Figure 7.2 The parameter as argument of a second-order function

The conceptual analysis led to the identification of four parameter roles, which were similar to the roles of ordinary variables:

- The parameter as *placeholder* represents a position, an empty place, where a numerical value can be filled in or retrieved from. The value in the ‘empty box’ is a fixed value, known or unknown, that does not change. This is the ground level of understanding the concept of parameter.
- The parameter as *changing quantity* concerns the systematic variation of the parameter value. The parameter acquires the dynamic character of a ‘sliding parameter’ that smoothly runs through a reference set (van de Giessen, 2002). This variation affects the complete situation – that is, the formula as an object, and the global graph – whereas variation of an ordinary variable only acts locally.
- The parameter as *generalizer* generalizes over a class of situations. By doing so, this ‘family parameter’ (van de Giessen, 2002) unifies such a class, and represents it. This generic representation allows for ‘seeing the general in the particular’, for the generic algebraic solution of categories of problems, and for formulations and solutions at a general level. This general solution of all concrete cases at once by means of a parametric general solution requires the reification of the expressions and formulas that are involved in the generic problem-solving process.
- The parameter plays the role of *unknown* when the task is to select particular cases from the general parametric representation on the basis of an extra condition or criterion. This often requires a shift of roles and of hierarchy (Bills, 2001).

The conceptual analysis and the theoretical framework provided means to define the higher level understanding of the concept of parameter. Fig. 7.3 visualizes this level structure. In terms of the Van Hiele levels, we considered the placeholder level as the ground level of understanding the concept of parameter that is the basis for the

second level. The three roles of changing quantity, generalizer and unknown share the property that formulas that contains them are considered as objects. Therefore, they are part of the second level understanding. The most important of the three was supposed to be the generalizer, as generalising is a key activity in algebra. The targeted higher level understanding, therefore, involved the jump from placeholder to the other parameter roles, ‘from Diophantus to Viète’, or in terms of the four-level structure (Fig. 7.1), the transition from the referential level to the general level.

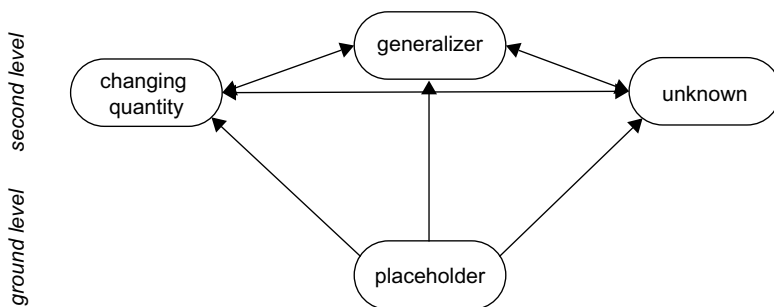

Figure 7.3 Levels of understanding the concept of parameter

The understanding of the higher parameter roles was supposed to require the reification of parametric expressions and formulas (Gravemeijer et al., 2000).

#### 7.4 The instrumental approach to using computer algebra

The question now is how computer algebra use can contribute to the higher level understanding of the concept of parameter.

Generally speaking, computer algebra environments were supposed to offer opportunities for algebra education. Unlike other IT tools, the CAS has a full repertoire of algebraic procedures and representations. By freeing the students from the algebraic calculations, computer algebra would offer opportunities to concentrate on concept development and on problem-solving strategies. CAS use might help students to distinguish between concepts and skills (Monaghan, 1993) and to readjust the balance between them (Heid, 1988; O’Callaghan, 1998).

The integration of CAS into algebra education also might introduce some pitfalls. Because the CAS already ‘contains all the algebra’, the computer algebra tool might have a somewhat abstract and formal top-down character, and might turn out to be inflexible with respect to informal notation and syntax. Furthermore, the CAS might be a black box for students, as it carries out complex procedures in a way that is not transparent to them. Finally, the CAS might seem to be a microworld to the students that is not connected to the world of real-life problems or that of paper-and-pencil

and mental mathematics (Drijvers, 2000).

For the purpose of understanding the concept of parameter, we identified the following CAS affordances. First, getting algebraic expressions as solutions to parametric equations and processing algebraic expressions further by means of substitution was expected to support the reification of algebraic expressions and formulas. Second, algebraic explorations that generated examples were supposed to foster generalization over these situations, thus opening the way for the parameter as generalizer. Third, the flexibility concerning literal symbols and their roles that the CAS offers could be used to change the parameter role into that of unknown. Finally, although not exclusive to the computer algebra environment, the availability of a slider tool was supposed to support the view of parameter as changing quantity.

For the teaching experiments, we had to choose a specific computer algebra tool. For practical reasons we decided to use the handheld TI-89 symbolic calculator: the students would be able to use it permanently at school as well as at home, and it would not require a reorganization of the lessons. The limitations of the screen resolution were mitigated by having some lessons in the computer lab, using the TI-Interactive software package. We hoped that the individual character of the handheld calculator would not hinder collaboration between students, and decided to have them work in pairs in order to obviate that problem.

As we announced in the description of the theoretical framework, we used the instrumental approach to computer algebra use as a framework for understanding and interpreting the student-machine interactions. The central idea of the instrumental approach to using IT tools is that a 'bare' tool or artifact is not automatically a useful instrument. While using such a tool, the user has to develop mental 'schemes of instrumented action', or – to put it somewhat shorter – instrumentation schemes (Artigue, 1997b, 2002; Guin & Trouche, 1999, 2002; Lagrange, 2000; Trouche, 2000). An instrument, according to this view, consists of the artifact (or a part of it), the mental scheme and the type of tasks for which it is appropriate (see Fig. 7.4).

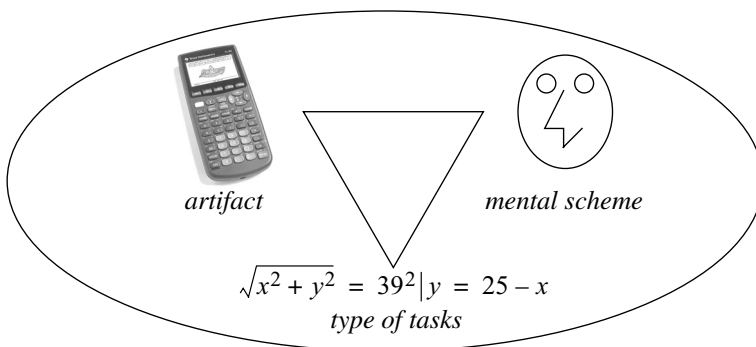

Figure 7.4 The instrument: a triad of artifact - mental scheme - task

The instrumentation schemes integrate technical skills and conceptual insights; difficulties in the development of the schemes – the instrumental genesis – often involve both aspects. As we cannot look insight the heads of the students to observe the mental schemes, we focused on the techniques, which can be considered as the observable parts of the instrumentation scheme, viz. the set of procedures in the environment that the students use for solving a specific type of problems.

In this study, the instrumental approach offered a framework to investigate the interaction between student and the computer algebra environment. The combination of technical and conceptual aspects within the instrumentation scheme made the theory promising for this purpose, because it both goes beyond the somewhat naive idea of reducing skills and reinforcing concepts, and takes seriously the difficulties of the instrumental genesis.

## 7.5 Methodology

We used a design research methodology in this study. Design research – which is also known as developmental research or development research – aims at developing theories and an empirically grounded understanding of ‘how learning works’ (Research Advisory Committee, 1996). Its main objective is to understand the students’ learning process. This connects with the character of our research questions, which start with ‘How can ... ’ and not with ‘Can ... ’. One characteristic of design research is the importance attributed to the design of instructional activities, which is seen as a meaningful part of the research methodology as it forces the researcher to be explicit about choices, hypotheses and expectations (Edelson, 2002). Another important feature of design research is the adaptation of the learning trajectory throughout the research: instructional sequences and teaching experiment conditions are adjusted according to previous experience. Therefore, design research was particularly suitable for this study, because a full theoretical framework was not yet available and hypotheses were to be developed. Adapting the experimental situation is possible by means of the cyclic design that is used in design research. A macro research cycle consists of a preliminary phase (which in our case included the development of a hypothetical learning trajectory and the design of instructional activities), a teaching experiment phase and a retrospective phase, which includes data analysis and leads to feed-forward for the next research cycle (Gravemeijer, 1994). This study consisted of three main research cycles – G9-I, G9-II and G10-II – and one intermediate cycle, G10-I. The 9 and 10 stand for the grades in which the teaching experiments were conducted. The I and II refer to the first and second cohort of students involved. The tenth-grade population was a subset of the ninth-grade population, with the exception of a few students who entered the teaching experiment in tenth grade (see Fig. 7.5).

We will now briefly explain each of the phases within one research cycle. In the *preliminary phase*, a hypothetical learning trajectory (HLT) was developed (Simon,

1995). This involved assessing the starting level of understanding, formulating the end goal and developing a chain of mental steps towards that goal, as well as instructional activities that were expected to bring about this mental development. This was accompanied by the designer's description of why the activities were supposed to work and what kind of mental developments were expected to be elicited. Because of its stress on the mental activities of the students and on the designer's motivation of the expected results, the HLT concept was a useful research instrument for monitoring the development of the hypotheses and for capturing the researcher's thinking.

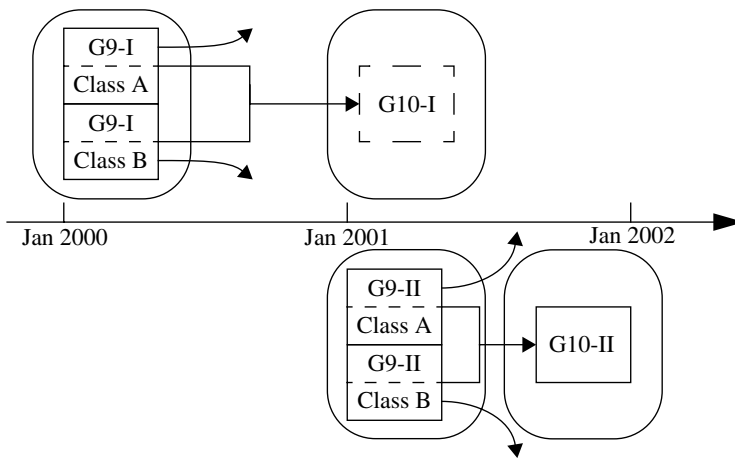

Figure 7.5 Arrangement of research cycles and teaching experiments

The development of the HLT was closely related to the design of instructional activities, which was done by using design heuristics such as guided reinvention, didactical phenomenology and mediating models. Key items in these instructional activities that would serve to monitor students' mental development in relation to the HLT were identified; also, questions for interviewing students on these key items were formulated and a prior global coding system for observations was developed.

The second phase of the design research cycle is the *teaching experiment phase* (Steffe, 1983; Steffe & Thompson, 2000). During the teaching experiments, we focused on data that reflected the learning process and provided insight into the students' thinking. The main sources of data, therefore, were observations of student behaviour and interviews with students. Most lessons were observed by two observers, who made field notes. The key instructional activities were assessed by means of mini-interviews with a selection of the students; video registrations were made of classroom discussions and of a selected pair of students. Written materials (notebooks, pretests and posttests) were gathered from all students. Altogether, 110 stu-

dents were involved, and over 100 lessons were observed.

The final phase of the research cycle is the phase of *retrospective analysis*. A first step in this phase was the selection and analysis of data. The initial method of analysis was inspired by the constant comparative method (Glaser & Strauss, 1967; Strauss, 1987; Strauss & Corbin, 1998). The first findings led to adaptation of the prior coding system. Then the data were coded. The coding process was partially done by two researchers, in order to achieve an intersubjective agreement. The conclusions of the data analysis were translated into feed-forward for the next research cycle. The feed-forward comprised changes in the HLT and in the instructional activities, and even slight changes in the focus of the subsequent teaching experiment.

## 7.6 Through the research cycles

Fig. 7.5 shows the arrangement of the design research cycles in this study. We will now briefly review each of these cycles, and the teaching experiments in particular. These teaching experiments were carried out at a school in Bilthoven, a town not far from the city of Utrecht.

The first research cycle (G9-I) included a teaching experiment that was carried out in two ninth-grade classes of the pre-university stream (in Dutch: vwo, 14- to 15-year-old students). The experiments ran for five weeks with four mathematics lessons each week. The HLT for these experiments followed the line parameter as placeholder-generalizer-changing quantity-unknown. The instructional activities were presented in two booklets: 'Introduction TI-89', which was intended to introduce the students to the use of the TI-89 symbolic calculator, and 'Changing algebra', which was intended to help them to develop an insight into the concept of parameter.

The results showed that generalization was hindered by instrumentation problems, in particular with a scheme for solving systems of equations. Fig. 7.6 shows this scheme of isolate-substitute-solve (ISS) for the system  $x + y = 31$ ,  $x^2 + y^2 = 25^2$ .

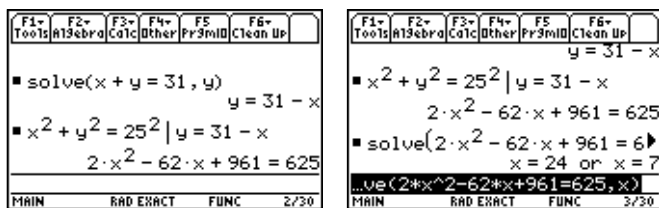

Figure 7.6 The isolate-substitute-solve scheme on the TI-89

In some cases students felt no need for generalization, or the generalization had a superficial character of pattern recognition without intrinsic understanding. The parameter as changing quantity was understood better, although we missed features for visualizing the dynamics on the TI-89. The parameter as unknown did not

receive much attention. The shift of roles of the parameter that was involved presented the students with difficulties. The substitution of expressions and the appearance of expressions as solutions of parametric equations supported reifying expressions and overcoming the lack of closure obstacle. The results of the posttest confirmed that both the generalization and the application of the ISS scheme were bottle-necks for many students. As feed-forward from the G9-I research cycle, we decided to reorder the global HLT line into placeholder-changing quantity-generalizer-unknown, in order to delay generalization until a more dynamic and hierarchic view of parameter was established. For this purpose, we aimed at finding a better means to represent the sliding parameter on the TI-89. To overcome instrumentation problems, we included practising simple instrumentation schemes for solving and substituting more extensively before integrating them into the composed ISS scheme.

The teaching experiment of the second research cycle (G9-II) was carried out in a second cohort of two ninth-grade classes of the pre-university stream (14- to 15-year-old students). The experiment was similar to the G9-I teaching experiment and ran for five weeks with four mathematics lessons each week. The HLT followed the line that emerged from the feed-forward from G9-I. The concept of parameter as changing quantity was supported by two TI-89 programmes called SHOOT and SLIDE. The student text included a part that introduced the students to the use of the TI-89 and a part that focused on developing an insight into the concept of parameter.

The results showed that the concept of parameter as changing quantity was supported by the SHOOT and SLIDE applications, although some students tended to see the parameter as running only through integer values. Starting the HLT with this parameter role was an improvement compared to the G9-I HLT. For generalization, we encountered similar difficulties as in G9-I, though to a lesser extent. Despite the attention to simple instrumentation schemes for solving and substituting, the composed ISS scheme still caused difficulties. Also, the students often did not feel the need for generalization, perhaps because of the abstract and complex problem situations. The parameter as unknown received more attention than it did in G9-I, but the complexity of the problem situations prevented the students from keeping track of the problem-solving strategy and the changing roles of the parameter therein.

The results of the posttest confirmed these findings, although the performance of the ISS instrumentation scheme and the generalizations with parameters slightly improved compared to the G9-I results. After the posttest, final interviews were held with 19 students. During these interviews the students did not have a symbolic calculator at their disposal. The results of these interviews suggested a transfer of substitution as a computer algebra technique to substitution as a paper-and-pencil technique, and an improved reification of expressions. For example, the students were able to substitute  $y = a - x$  into  $x^2 + y^2 = 10$  by hand, and one of them used the TI-89 notation for substitution while doing so (Fig. 7.7).

As feed-forward from the G9-II research cycle, we first noted that the global HLT along the line placeholder-changing quantity-generalizer-unknown was adequate and needed no further change. For the parameter as changing quantity, the use of a continuous slider tool might be used to avoid the notion of a discrete reference set.

$$\begin{array}{l} y = a - x \\ \underline{x^2 + y^2 = 10} \quad | \quad y = a - x \end{array}$$

Figure 7.7 Transfer of notation

The findings suggested that the parameter as generalizer might be better addressed without the complication of the instrumentation of the ISS scheme. This required looking for problem situations that could be solved with one equation rather than with a system of two equations. Furthermore, the problem situations were targeting the general level too directly. The use of realistic contexts in which the parameter would have a meaning to the students might lead to easier and more meaningful generalizations, and would address the referential rather than the general level. Graphs might be used as contexts as well, and could be useful for the transition from the parameter as changing quantity to the parameter as generalizer. The use of realistic problem situations might also address the parameter as unknown in a more natural way.

The G10-I intermediate cycle included a five-lesson teaching experiment in tenth grade. These students had opted for the exact stream and all but one had participated in G9-I as well. Because of a lack of time and the full regular curriculum in tenth grade, this intermediate cycle rather was more of a short ‘finger exercise’ for G10-II than a full research cycle. The results showed that the students easily recalled the TI-89 skills they had learned a year earlier. Once more, using a slider tool for the parameter as changing quantity was preferred to replacing parameter values by substitution.

The third and last complete research cycle (G10-II) included a 15-lesson teaching experiment in one tenth-grade class of the exact stream of pre-university stream. All but two students had participated in the G9-II teaching experiment. In accordance with the feed-forward from G9-II, we stuck to the global trajectory of placeholder-changing quantity-generalizer-unknown. For the parameter as changing quantity, the continuous slider tool of the TI-Interactive software package was used. To address meaningful parameters and formulas and natural generalizations, realistic problem situations were more prominent than in the instructional activities of the previous teaching experiments. We expected this would also improve the understanding of the parameter as unknown.

The results showed that the use of the continuous slider tool improved the perception

of the changing parameter running through a continuum. Contexts in which the parameter had an evident meaning in the graph allowed for meaningful generalizations. Realistic contexts also improved insight into the meaning and structure of formulas and expressions. Meanwhile, entering complex expressions with fractions and powers and recognizing equivalent expressions provided difficulties. The fact that the problem situations led to one rather than to two equations averted the difficulties of the ISS instrumentation scheme. The parameter as unknown was addressed with more success than in previous experiments, probably also due to the more meaningful problem contexts. However, the complexity of the formulas involved seemed to be a crucial factor.

The results of the final task that ended the G10-II teaching experiment were positive. Many appropriate generalizations were found and the students dealt adequately with complex formulas. The realistic problem situation on the speed of a traffic flow helped them to give meaning to the results.

## 7.7 Results on computer algebra use and the concept of parameter

The first research subquestion of this study concerns the contribution of computer algebra use to a higher level understanding of the concept of parameter. This higher level understanding was defined as insight into the higher parameter roles of changing quantity, generalizer and unknown. We will now summarize the results on this issue.

As expected from our conceptual analysis, the placeholder view of the parameter was the starting level for almost all students. To extend this concept to the role of *changing quantity*, the computer algebra environment allowed for changing the parameter values one by one. Investigating the dynamic effects of the ‘sliding parameter’ by means of a slider tool – which is not an exclusive CAS feature – proved to be more efficient. This led to the perception that parameter change affected the complete situation and the graph as a whole, and was a second-order change. If the parameter had a meaning to the student in the context or as a graphical property, examining the sliding graph invited algebraic verification and generalization. However, there was a risk of only superficial examination without reflection or verification. Furthermore, the parameter as changing quantity tended to dominate the students’ view of parameter, so that they sometimes seemed to forget the other parameter roles. Altogether, a higher level understanding of the parameter as changing quantity was achieved.

The work in the computer algebra environment supported the transition to the parameter as *generalizer* by allowing the repetition of similar procedures for different parameter values. This generated examples that were the basis for generalization and for solving parametric equations. The fact that parametric equations led to expressions rather than numerical solutions fostered the reification of expressions and formulas, and the overcoming of the lack of closure obstacle. The dynamic

graphs that appeared from the work with the sliding parameter in some cases elicited generalization, for example in the case of the graph of  $y = (x - a)^2 + a$ . One pair of students noticed that the vertex of the graph had coordinates  $(a, a)$  for all values of  $a$ . One of them commented that ‘the vertex is at  $a$ ’ and that ‘the  $y$ - and  $x$ -coordinates are the same as  $a$ ’. Later, during the whole-class discussion, the other student explained this generalization by referring to an exemplary parameter value.

*Maria: Yes, I think that vertex, that were the  $x$  and  $y$  coordinates, they were, so to say, equal to the  $a$ . The vertex was  $(1, 1)$ , then  $a$  was  $1$  too.*

Many students achieved a higher level understanding of the parameter as generalizer only to a limited extent. In some cases, the students did not feel the need for generalization. In other cases, generalization came down to phenomenological pattern recognition without intrinsic understanding. The instructional activities were aimed too directly at the general level, and the formulas in some cases were too complex. Finally, instrumentation problems hindered generalization. The essential step of generalising relations – in which parameters are used to unify a class of situations – seemed to be primarily a mental one, upon which computer algebra had hardly any influence.

The possibility to solve equations in the computer algebra environment with respect to any unknown improved the students’ flexibility concerning the roles of the literal symbols. The results on parameter as *unknown* were mixed: although this parameter role was understood in simple cases, in more complex ones the students failed to distinguish the changing roles and meanings of the variables and parameters. The change in the hierarchy between variable and parameter in complex cases was more difficult to keep track of.

Two issues seemed to influence the development of the higher level understanding of the concept of parameter: the use of realistic problem situations and the insight into the meaning and structure of expressions and formulas. We have already mentioned the importance of *realistic problem situations*. Despite our initial ideas, using the CAS as a mathematical environment that would make references to reality redundant, did not work out for the students of this age and level. Addressing the general level directly did not work out either, because the students had not yet developed an appropriate mathematical framework. Instead, they needed meaning for parameters, expressions and formulas from the realistic problem situation at a referential level. Meanwhile, realistic problem situations did not hinder generalization and abstraction beyond these specific contexts.

The *expressions and formulas* that the students encountered were more complex than usual because of the presence of parameters. The CAS output, whether algebraic

or graphical, invited a closer inspection of the formulas and expressions involved, particularly when this was suggested by the task or by the teacher. Entering complex formulas required insight into the algebraic structure of the formulas and expressions. Therefore, although insight into the meaning and structure of expressions and formulas was an obstacle during the CAS work, such work seemed to improve the insight. The work in the computer algebra environment also supported the development of symbol sense, the reification of formulas and expressions, and the overcoming of the lack of closure obstacle. As an overall conclusion on the contribution of computer algebra use to a higher level understanding of the concept of parameter, we did indeed find that the CAS activities contributed to the development of insight into the different parameter roles. This contribution was more evident for the parameter as changing quantity than for the generalizer and the unknown. Furthermore, the reification of formulas and expressions was supported. In the meantime, we found that realistic starting points were indispensable for meaningful work in the computer algebra environment.

Several factors might optimise the targeted learning process. First, the data from the final teaching experiment suggest that it might be fruitful to integrate rather than separate the different parameter roles, so that the students develop a more integrated view of the parameter. Second, we noticed that starting with models that refer to concrete problem situations leads to better results with students of this age and level. Third, we conjecture that the contribution of computer algebra to the conceptual development would improve if it were used for a longer period, so that instrumentation difficulties were less dominant. Finally, we think that whole-class discussions, guided by the teacher, might have stimulated the collective conceptual development to a greater extent. We notice that the teachers considered the student cohorts involved in this study as weak cohorts. They might have needed more guidance. The difficulties the students encountered while working with the CAS suggest that the instrumentation process is important. We will discuss this issue in the next section.

## 7.8 Results concerning the instrumentation of computer algebra

The second research subquestion concerned the instrumentation of computer algebra and the relation between computer algebra techniques and conceptual development. We will now summarize the results of this study on this issue.

As simple instrumentation schemes, the solve scheme and the substitute scheme were investigated. For both schemes, which are related to the concept of parameter, the instrumental genesis involved the extension of conceptual understanding. For the *solve* scheme, the syntax and the application to parametric equations led the students to realize that an equation is always solved with respect to an unknown, that solving a parametric equation leads to expressing one variable in term of others, and that the solution in that case is an expression. For *substitution*, the substitution of expressions

within the computer algebra environment led the students to extend their conceptual understanding with the notion that only isolated forms can be substituted, and that expressions can be considered as ‘things’ that can be ‘pasted’ into a variable. In line with Sfard’s ideas, the operation on the expression enhances its object character (Sfard, 1991).

Although the instrumental genesis of the solve and substitute schemes seemed to progress smoothly, combining them into the composed *isolate-substitute-solve* (ISS) scheme caused persistent difficulties. This indicated that the integration of simple schemes into a more comprehensive scheme requires a high level mastering of the component schemes. The instrumental genesis apparently needed more time than was given to the students.

We identified a number of obstacles that hindered the instrumental genesis, such as the way in which the CAS deals with the difference between numerical approximations and exact algebraic results, the difficulties with entering expressions containing parentheses, square root signs and powers, and interpreting results. Recognizing the equivalence of CAS output and expected results was a difficult issue. Although many of these obstacles were related to a lack of symbol sense, they also fostered its development. And although the students’ lack of insight into the structure of expressions and formulas led to errors in the CAS work, these problems stimulated a closer look at these structures. In that sense, obstacles also provided opportunities for learning, when managed appropriately by the teacher.

Some of the observed difficulties with entering expressions and interpreting algebraic results were related to the paper-and-pencil work that the students were used to. Incongruence between computer algebra technique and paper-and-pencil technique explained some of the instrumentation problems. When the techniques in the two media were congruent, the transfer of notation, strategy and technique between the paper-and-pencil and computer algebra environments was observed. An explicit comparison between computer algebra technique and paper-and-pencil method was effective for making students record the degree of congruence. A second condition for transfer was the transparency of the computer algebra technique: when the students were able to understand the way in which the CAS arrived at its results rather than perceiving it as a black box, transfer to the paper-and-pencil work took place. The data indicate that the students developed different preferences concerning paper-and-pencil work versus work in the computer algebra environment.

The teacher played an important role in the instrumental genesis. Different teacher behaviour led to different instrumented techniques. Whole-class demonstrations and discussions proved to be important for collective instrumentation; this aspect of instrumentation should have received more attention in the teaching experiments. Furthermore, a new didactical contract had to be established concerning the relation between by-hand work and machine work, and between numerical-graphical methods and algebraic methods. The fact that for the teachers the integration of computer

algebra technology into teaching was new and lasted for a short period made it hard to establish a new didactical contract and to foster collective instrumental genesis. Overall, the results of this study suggest a close and reciprocal relation between CAS techniques and conceptual understanding. Students had to build up instrumentation schemes that combined technical and conceptual aspects. This instrumental genesis required time and effort, and obstacles had to be overcome. Seemingly technical difficulties were often related to a lack of conceptual understanding. Paper-and-pencil routines were also involved in this relationship. As consequences for teaching, we recommend developing a new didactical contract, fostering collective instrumentation by means of whole-class discussions and demonstrations, and discussing the congruence or incongruence between paper-and-pencil and CAS techniques.

## **7.9 CAS use and the learning of algebra in general**

In this section we first discuss the conclusions concerning the main research question. Then follows a reflection on the study. We conclude with some recommendations.

### *Conclusions*

The main research question concerns the contribution of computer algebra use to understanding algebraic concepts and operations in general. By means of extrapolating the answers to the two research subquestions to this more general level, we conclude the following.

First, some of the findings not only concern the understanding of the concept of parameter, but also show that computer algebra use can contribute to the understanding of algebraic concepts and operations in general. Symbol sense could be developed, as could insight into the meaning and structure of formulas and expressions. Algebraic notions were extended. Computer algebra offered affordances for combining different representations, repeating procedures as a preparation for generalization, and dealing with expressions as objects. Critical for capitalising on these affordances were the didactic embedding and the use of meaningful formulas that referred to realistic problem situations, rather than to the general level directly.

Second, the observed instrumental genesis of CAS instrumentation schemes, provided that it was orchestrated adequately, included conceptual development concerning algebra in general. The development of the solve scheme and the substitute scheme led to new insights into solving and substituting. Although incomplete instrumentation hindered learning, instrumentation obstacles provided learning opportunities. Conditions that fostered the instrumentation of computer algebra were the congruence between CAS technique, mental conception and paper-and-pencil technique, and the transparency of CAS procedures. These turned out to be hard issues, as some CAS procedures were not transparent to the students, and CAS nota-

tions and syntax differed from what the students were used to from paper-and-pencil experience.

When we compare these findings with our initial expectations, we notice that the instrumentation difficulties were more persistent than we had expected, and that the role of the teacher was more important than we had foreseen.

Furthermore, our ideas on focusing on the general rather than on the referential level did not come true, and realistic problems could not be missed as starting points. What is realistic to students depends on their age and level: we conjecture that students in advanced mathematics can more easily experience the CAS as a realistic environment on its own.

### *Reflection*

When we look back at this study, what can we say about the role of theory in it, about the methodology that we used and about the generalizability of the results? We will first look back at the elements of the *theoretical framework*.

The domain-specific instruction theory of *Realistic Mathematics Education* helped us to understand why the students needed realistic problem situations to start with: the algebraic objects and procedures were not yet part of an appropriate network of mathematical relations. The distinction of the referential level and the general level (see Fig. 7.1) clarified our goals as well as the difficulties that the students encountered. The notions of horizontal and vertical mathematization made it clear why generalization and abstraction did not work out on many occasions. Finally, the RME view was helpful in understanding the problem of the black box character of using the CAS.

The *level theories* acted as background for defining the higher level understanding of the concept of parameter and helped in developing the learning trajectory and for designing instructional activities.

We defined *symbol sense* as insight into the structure and meaning of formulas and expressions. Looked at in this way, it was a means of interpreting the students' behaviour with formulas and expressions in the computer algebra environment: symbol sense was a prerequisite to productive CAS use, but could also develop from it. As feedback to the theoretical notion of symbol sense, we would suggest that it needs a more precise definition.

*Theories on symbolizing* made it clear that the character of the computer algebra environment and the initial choices of this study did not offer much opportunity for a bottom-up signification process. However, the instrumentation of computer algebra fostered the development of meaningful mathematical objects, and of a framework of mathematical relations, which was connected with symbols and expressions that the students encountered while working in the computer algebra environment. Therefore, the relation between the instrumentation approach and theories on symbolizing deserves further investigation.

The *process-object duality* was useful for identifying the influence that computer algebra use had on the development of an object view of formulas and expressions by the students. Together with the notion of symbol sense, reification was a frame of reference for monitoring the progress of algebraic insight into formulas and expressions.

The *theory of instrumentation* helped us to interpret student behaviour in the computer algebra environment and to observe the relation between technical and conceptual components within instrumentation schemes. Sometimes the instrumental genesis was hindered by conceptual barriers, but at other times it fostered further conceptual development, as was suggested by the theory. This study worked out some concrete schemes and stressed the relevance of the congruence and transparency criteria. We suggest paying more attention to the link between the computer algebra technique and the corresponding paper-and-pencil technique.

Altogether, we see that most of the elements of the theoretical framework contributed to this study, despite the fact that the elements of the framework – except for the instrumental approach – were not dedicated for use in the context of this study. One of the main results of this study for the theoretical framework, therefore, is the theories' perceived contribution in a setting for which they were not developed, which suggests a wide applicability.

How do we look back at the *methodology*? Reflecting on this, we feel that the design research paradigm was appropriate for the purpose of this study. The cyclic character allowed for adapting experimental settings, and the design of the learning trajectory and instructional activities served for making explicit our intentions. In the preliminary phase, the hypothetical learning trajectory was a productive way of monitoring the development of the hypotheses and expectations throughout the research. Prior identification of key items and their expected outcomes in the design phases guided classroom observations during the teaching experiments and data analysis in the retrospective phases. The mini-interviews on these key items provided relevant data, although this data gathering technique required a good attunement with the teacher and refrainment from playing the role of assistant teacher. The whole-class videos did not contribute much to the data, as the whole-class discussions in most cases did not address the key items or concepts that we wanted to observe. In the retrospective phase, the data analysis method – which combined a prior coding system with an approach similar to the constant comparative method – was effective. Working together with a second researcher who coded the data independently improved both the quality of the data analysis and the coding system. The method of formulating feed-forward for the next research cycle was helpful for capturing research progress. How about the *generalizability* of the findings? Do the findings of this study depend on the specific choices that were made, or can they be generalized to other situations? Many issues that showed up in this study – such as the reification of formulas and expressions, and the development of symbol sense – are not specific to the con-

cept of parameter. Therefore, we think that the scope of these findings exceeds the understanding of the concept of parameter and can be generalized to learning algebra in general. We also think that the conclusions can be generalized as regards instrumentation. Despite differences between computer algebra environments at a detailed level, these systems are based on common principles and similar instrumentation issues play a role. The question whether the instrumental approach can be applied to other IT environments deserves further research.

Generalization to other Dutch schools can be made as well, as long as the specific educational setting is taken into account. Generalization to CAS use in other grades should be considered with care. We expect more instrumentation problems to appear in lower grades, and we recommend longer periods of CAS use in ninth and tenth grades. For higher grades, we expect similar instrumentation issues and affordances to play a role, and we conjecture that in those grades the students will have more mathematical means for overcoming obstacles and benefiting from opportunities.

### *Recommendations*

The conclusions of this study led to recommendations for teaching, for software design and for further research. As regards *teaching algebra using computer algebra*, the results suggest that it is important to anticipate on computer algebra use, to be explicit about the changing didactical contract, to orchestrate individual and collective instrumentation, to have students compare CAS techniques with paper-and-pencil techniques and to have students reflect on the way CAS works.

As for *designing algebra software* for educational purposes, we recommend taking care of the criteria of the transparency and congruence of the technological environment. The black box character and idiosyncratic features inhibit instrumentation. Flexibility with regard to notations, syntax and strategy is a third criterion that should be met.

As regards *further research* on learning mathematics in a technological environment, we recommend taking into account the complete pedagogic situation rather than investigating the use of the technological environment as an isolated phenomenon, so that the social and the psychological perspective can be coordinated (Yackel & Cobb, 1996). Here, the cultural-historical activity theory – which considers tool use as embedded in a social practice – could provide a fruitful additional perspective. Furthermore, the relation between the instrumental approach and theories on symbolizing would be an interesting starting point for further theoretical development. A longitudinal study on symbolizing in a computer algebra environment, including adequate teaching that prepares for computer algebra use, is recommended. The extension of the scope of this study to other mathematical topics – such as the concept of function – and to other IT tools – such as software for dynamic geometry or Java applets – is also recommended. Finally, the role of technology in assessment requires further study.

## References

- Arcavi, A. (1994). Symbol sense: Informal sense-making in formal mathematics. *For the Learning of Mathematics*, 14(3), 24-35.
- Artigue, M. (1997). Rapports entre dimensions technique et conceptuelle dans l'activité mathématique avec des systèmes de mathématiques symboliques. [Relations between the technical and conceptual dimensions in mathematical activity with systems of symbolic mathematics.] *Actes de l'université d'été 1996* (pp. 19-40). Rennes, France: IREM de Rennes.
- Artigue, M. (2002). Learning mathematics in a CAS environment: The genesis of a reflection about instrumentation and the dialectics between technical and conceptual work. *International Journal of Computers for Mathematical Learning*, 7, 245-274.
- Bednarz, N., Kieran, C. & Lee, L. (Eds.) (1996). *Approaches to algebra, perspectives for research and teaching*. Dordrecht, Netherlands: Kluwer Academic Publishers.
- Bills, L. (2001). Shifts in the meanings of literal symbols. In M. van den Heuvel-Panhuizen (Ed.), *Proceedings of the 25th conference of the international group for the psychology of mathematics education, Vol 2* (pp. 161-168). Utrecht, Netherlands: Freudenthal Institute.
- Bloody-Vinner, H. (2001). Beyond unknowns and variables - parameters and dummy variables in high school algebra. In R. Sutherland, T. Rojano, A. Bell & R. Lins (Eds.), *Perspectives on school algebra* (pp. 177-189). Dordrecht, Netherlands: Kluwer Academic Publishers.
- Boyer, C.B. (1968). *A history of mathematics*. New York: Wiley.
- Chick, H., Stacey, K., Vincent, Ji. & Vincent, Jo. (Eds.) (2001). *Proceedings of the 12th ICMI study conference the future of the teaching and learning of algebra*. Melbourne: The University of Melbourne.
- Collis, K.F. (1975). *The development of formal reasoning*. Newcastle, NSW: University of Newcastle.
- Drijvers, P. (2000). Students encountering obstacles using a CAS. *International Journal of Computers for Mathematical Learning*, 5, 189-209.
- Dubinsky, E. (1991). Reflective abstraction in advanced mathematical thinking. In D. Tall (Ed.), *Advanced mathematical thinking* (pp. 95-123). Dordrecht, Netherlands: Kluwer Academic Publishers.
- Edelson, D.C. (2002). Design research: What we learn when we engage in design. *Journal of the Learning Sciences*, 11(1), 105-121.
- Freudenthal, H. (1983). *Didactical phenomenology of mathematical structures*. Dordrecht, Netherlands: Reidel.
- Furinghetti, F. & Paola, D. (1994). Parameters, unknowns and variables: A little difference? In J.P. Da Ponte & J.F. Matos (Eds.), *Proceedings of the 18th international conference for the psychology of mathematics education, Vol 2* (pp. 368-375). Lisbon: University of Lisbon.
- Giessen, C. van de (2002). The visualisation of parameters. In M. Borovcnik & H. Kautschitsch (Eds.), *Technology in mathematics teaching. Proceedings of ICTMT5* (pp. 97-100). Vienna: Oebv&hpt Verlagsgesellschaft.
- Glaser, B. & Strauss, A. (1967). *The discovery of grounded theory. Strategies for qualitative research*. Chicago: Aldine.
- Gravemeijer, K. (1994). *Developing realistic mathematics education*. Utrecht: CD-β Press.
- Gravemeijer, K. (1999). How emergent models may foster the constitution of formal mathematics. *Mathematical Thinking and Learning*, 1, 155-177.
- Gravemeijer, K.P.E., Cobb, P., Bowers, J. & Whitenack, J. (2000). Symbolising, modeling, and instructional design. In P. Cobb, E. Yackel & K. McClain (Eds.), *Symbolising and communicating in mathematics classrooms: Perspectives on discourse, tools, and instructional design* (pp. 225-273). Hillsdale, NJ: Lawrence Erlbaum Associates.
- Guin, D. & Trouche, L. (1999). The complex process of converting tools into mathematical instruments: The case of calculators. *International Journal of Computers for Mathemati-*

- cal Learning*, 3, 195-227.
- Guin, D. & Trouche, L. (2002). Mastering by the teacher of the instrumental genesis in CAS environments: Necessity of instrumental orchestrations. *Zentralblatt für Didaktik der Mathematik*, 34(5), 204-211.
- Harper, E. (1987). Ghosts of Diophantus. *Educational Studies in Mathematics*, 18, 75-90.
- Heid, M.K. (1988). Resequencing skills and concepts in applied calculus using the computer as a tool. *Journal for Research in Mathematics Education*, 19, 3-25.
- Hiele, P.M. van (1973). *Begrip en inzicht, werkboek van de wiskundendidactiek*. [Meaning and insight, work book of didactics of mathematics.] Purmerend, Netherlands: Muusses.
- Hiele, P.M. van (1986). *Structure and insight, a theory of mathematics education*. Orlando, FLA: Academic Press Inc.
- Küchemann, D.E. (1981). Algebra. In K.M. Hart (Ed.), *Children's understanding of mathematics: 11-16* (pp. 102-119). London: John Murray.
- Lagrange, J.B. (2000). L'intégration d'instruments informatiques dans l'enseignement: une approche par les techniques. [The integration of technological instruments in education: an approach by means of techniques.] *Educational Studies in Mathematics*, 43, 1-30.
- Lange Jzn, J. de (1987). *Mathematics, insight and meaning*. Utrecht, Netherlands: OW&OC, Rijksuniversiteit Utrecht.
- Monaghan, J. (1993). New technology and mathematics education: New secondary directions. In A. Orton & G. Wain (Eds.), *Issues in mathematics education* (pp. 193-209). London: Cassell.
- O'Callaghan, B.R. (1998). Computer-intensive algebra and students' conceptual knowledge of functions. *Journal for Research in Mathematics Education*, 29, 21-40.
- Research Advisory Committee (1996). Justification and reform. *Journal for Research in Mathematics Education*, 27, 516-520.
- Sfard, A. (1991). On the dual nature of mathematical conceptions: Reflections on processes and objects as different sides of the same coin. *Educational Studies in Mathematics*, 22, 1-36.
- Simon, M.A. (1995). Reconstructing mathematics pedagogy from a constructivist perspective. *Journal for Research in Mathematics Education*, 26, 114-145.
- Steffe, L.P. (1983). The teaching experiment methodology in a constructivist research program. In M. Zweng, T. Green, J. Kilpatrick, H. Pollak & M. Suydam (Eds.), *Proceedings of the fourth international congress on mathematics education* (pp. 469-471). Boston: Birkhäuser Inc.
- Steffe, L.P., & Thompson, P.W. (2000). Teaching experiments methodology: Underlying principles and essential elements. In R. Lesh & A.E. Kelly (Eds.), *Research design in mathematics and science education* (pp. 267-307). Hillsdale, NJ: Erlbaum Associates.
- Strauss, A.L. (1987). *Qualitative analysis for social scientists*. Cambridge: Cambridge University Press.
- Strauss, A. & Corbin, J. (1998). *Basics of qualitative research. techniques and procedures for developing grounded theory*. Thousand Oaks, CA: Sage Publications.
- Tall, D. & Thomas, M. (1991). Encouraging versatile thinking in algebra using the computer. *Educational Studies in Mathematics*, 22, 125-147.
- Treffers, A. (1987a). *Three dimensions, a model of goal and theory description in mathematics instruction - the Wiskobas Project*. Dordrecht, Netherlands: D. Reidel.
- Treffers, A. (1987b). Integrated column arithmetic according to progressive schematisation. *Educational Studies in Mathematics*, 18, 125-145.
- Trouche, L. (2000). La parabole du gaucher et de la casserole à bec verseur: étude des processus d'apprentissage dans un environnement de calculatrices symboliques. [The parable of the left-handed and the skillet: Study on the learning process in a symbolic calculator environment.] *Educational Studies in Mathematics*, 41, 239-264.
- Yackel, E. & Cobb, P. (1996). Sociomath norms, argumentation, and autonomy in mathematics. *Journal for Research in Mathematics Education*, 27, 458-477.

---

## 8 A Gateway to Numeracy

*Mieke van Groenestijn*

### 8.1 Background Information

This chapter reports on a research project on numeracy in adult education, which was carried out in 1997 - 2001.

The population in adult basic education (ABE) in the Netherlands is only a small part of the total population in adult education (about 10%). Most of the learners in ABE are second language learners (about 80%). Hence ABE focuses mainly on learning Dutch and becoming familiar with the Dutch society. The direct purpose of ABE is that learners stream on to vocational education and to the labor market as soon as possible. The fact that mathematics, or numeracy, is also a precondition for success in vocational education and work is of less interest. However, internationally, interest in mathematics and numeracy for adults has been growing in recent years. Results of studies in the U.S.A. and international comparative studies show that numeracy is of real international concern, i.e. the Young Adult Literacy Survey in 1986 (YALS) and the National Adult Literacy Survey in 1992 (NALS) in the U.S.A., and the following International Adult Literacy Survey (IALS) in 1996 (Van der Kamp and Scheeren, 1996, Dossey, 1997, OECD, 1997, NCES, 1998, Houtkoop, 1999).

The IALS comparative study was held in twelve countries, the Netherlands among them. In these surveys information was acquired on three scales: prose literacy, document literacy and quantitative literacy. The results were shocking. According to the YALS, for example, about 40% of the young adults (age 21-25) could correctly compute the change they should get back from an amount tendered after having received the bill for a meal in restaurant and having computed 10% for the tip they should leave. Only one in five could read a bus schedule. The results on YALS showed that *“young adults lack many of the ‘walking around’ quantitative skills we would expect of almost any citizen”* (Dossey, 1997, p.46-47. Between one-third and half of the population achieved low on the scale of quantitative literacy in all three surveys. (Van der Kamp and Scheeren, 1996, Dossey, 1997, Houtkoop 1999). This indicates that these adults may have big problems with the interpretation of and giving meaning to quantitative information. Hence they may be hampered in their functioning in personal and societal life and work. The results of these studies showed that literacy and numeracy are still of great concern in western countries.

These studies made clear that adults also need to have mastered some numeracy skills in addition to literacy skills, even though one might suspect the opposite with all technological developments in the past decades. After all, technological means have been developed to liberate us from many mathematical tasks. On the contrary, due to the developments of technological tools, new mathematical skills are required for being able to deal with such new tools. Hence the question emerges what numer-

acy skills adults should have acquired to be numerate in personal life, society and work. In addition, in order to keep up with these technological developments, the need for lifelong learning has become clear. Consequently the need for the development of numeracy programs has been growing.

## 8.2 Research Questions

Internationally, numeracy education to adults in ABE has a short history and is mainly built on experiences in mathematics education to children. Very often numeracy courses consist of just teaching mathematics. The difference between numeracy and mathematics in adult education is often not clear. Sometimes the two words are just used as synonyms. In the Netherlands the word “numeracy” [in Dutch “gecijferdheid”] is hardly used in adult education. Internationally, teachers in adult education struggle how to organize numeracy courses that satisfy the wishes and needs of adults and that make sense in the frame of adult numeracy. The quality of programs often depends on the capability and experiences of individual (voluntary) teachers. There is little or no theoretical foundation for adult numeracy courses and no common base how to organize such courses. The existence of standards, curricula and national reporting systems is no guarantee for the quality of local numeracy courses. Little is known about the effectiveness of numeracy courses in ABE. Hence the main question in this study is:

What content should be offered in a numeracy program for learners in adult basic education and how should it be organized?

This question was explored along six research questions:

- 1 What is numeracy?
- 2 What mathematical content should be offered to adults in ABE to be equipped for the future?
- 3 How do we assess the learners’ mathematical knowledge and skills when they enter ABE?
- 4 What mathematical knowledge and skills have adults acquired when they enter ABE?
- 5 What way of learning and teaching mathematics could be appropriate for adults in ABE?
- 6 How to develop a program for functional numeracy education in Adult Basic Education that prepares adults to be equipped for the future?

To find answers to these questions four subjects were explored and elaborated thoroughly in four sub-studies. The first three studies provide the building blocks for the fourth study.

The first study concerns the questions “What is numeracy?” and “Who are the learners in ABE?”. Here the focus is on the development of adult basic education in gen-

eral, on the concept of numeracy and on the problematique concerning numeracy in ABE.

In the second study the emphasis has been laid on the question “What do learners in ABE know about mathematics when they enter ABE?” To answer this question we may first wonder how to assess adults and what kind of assessment tools are appropriate to acquire information about the learners’ mathematical knowledge and skills when they enter ABE. After that we will go into depth about the actual mathematical knowledge and skills of a group learners in ABE.

In the third study the focus is on the development of a theoretical basis for learning mathematics by adults in ABE in the frame of functional numeracy.

In the fourth sub-study a framework has been developed for a program on functional numeracy education for learners in ABE, based on the information acquired in the first three sub-studies.

### 8.3 Setting

Central in this study are a group of low-schooled second language learners in ABE at the Regional Education Center Utrecht, department Nieuwegein, in the Netherlands. After about four months intensive language training these learners were strongly advised to do a numeracy course to be better prepared for vocational education and work. The learners would first take a math test in December 1997. In discussion with the learning center the learners took two tests: the new national *Cito* math test for adults and the experimental *In Balance* placement test, both published in 1996<sup>1</sup>. This was done to be able to compare both tests on feasibility, effectiveness and results. With those two tests qualitative information could be acquired about the mathematical knowledge and skills of these adults at the start of a numeracy course. After that the learners were offered a six-week program on percentages for one hour per week, based on the *In Balance* instruction materials. The program was finished with a post test, composed of the same *Cito* and *In Balance* percent tasks as at the placement test, and with some interviews with individual learners.

The results on both tests and the learning experiences during the course are the empirical ingredients for this study. They show the characteristics of these learners and serve as the seeds in a breeding ground for development of a theory on learning and teaching mathematics in ABE.

---

1. The *Cito* mathematics test for adults was developed as part of a series of independent tests for the new system of adult and vocational education by the national center for development of test materials *Cito*. The mathematics test was published in 1996. (*Cito*, 1996) The *In Balance* placement test was published as part of the *In Balance* series, a set of instruction materials and tests on mathematics for adults in ABE. This series was published in the years 1996-2000 (Van Groenestijn et al, 1996, 1999, 2000).

## 8.4 Characteristics of this Study

The study can be characterized by the following features:

### *Exploratory and descriptive*

This study is exploratory and descriptive in a threefold way. First, it explores the concept of numeracy and its meaning for adults in personal life, society and work. It describes research done into adult numeracy. Second, it pictures the numeracy knowledge and skills of a relatively unknown population in adult basic education. Third, this study explores, analyses and sketches the field of numeracy education in adult basic education.

### *Qualitative analytic*

Results of adult learners in adult basic education on mathematics placement tests and observations concerning their learning of mathematics in classroom sessions have been analysed. This analysis yields much qualitative information that serves as ingredients for theory building and program development for functional numeracy.

### *Theory oriented*

A study of theories about learning by adults in general and of theories about learning of mathematics in particular, provides points of departure for theory building and an instructional model for numeracy learning and teaching in adult basic education.

### *Developmental*

The information acquired in the first three sections in this study has been used for the development of a numeracy program that should lead to functional numeracy.

This study aims to contribute qualitatively to the development of knowledge in the field of functional numeracy and the learning of mathematics by under-schooled adults in Adult Basic Education.

## 8.5 Conclusions and Discussion

### ***What is numeracy?***

The literature study in this research made clear that numeracy is a dynamic concept that changed over the years and may also change in the future. The concept of numeracy includes an increasingly broader content. Where it originally covered being familiar with numbers and doing operations with numbers in real life situations, as part of mathematics, it now includes mathematics and focuses on managing mathematical situations in real life. The mathematical content of numeracy changed over the years, due to technological developments and new societal demands. Hence

a working definition of numeracy must include the ability to adjust existing knowledge and skills flexibly to new future demands. Therefore, the working definition of numeracy in this study is a synthesis of what was found in the literature and focuses on future demands:

Numeracy encompasses the knowledge and skills required to effectively manage mathematical demands in personal, societal and work situations, in combination with the ability to accommodate and adjust flexibly to new demands in a continuously rapidly changing society that is highly dominated by quantitative information and technology.

Within this definition we distinguish three levels of numeracy:

- *Elementary numeracy* encompasses minimal knowledge and skills necessary for managing personal everyday life situations and for functioning in simple work situations with perhaps a little help from others.
- *Functional numeracy* encompasses a broader set of functional mathematical knowledge and skills, including elementary numeracy skills, enabling people to manage their personal and their families' societal life and work situations effectively and autonomously and to be a critical citizen.
- *Optimal numeracy* encompasses all extra mathematical knowledge and skills, in addition to people's functional numeracy skills, for acting in broader societal and/or political communities, higher professions, and leisure activities.

To make this definition operational for adult education four components are distinguished: mathematical knowledge and skills, management skills, skills for processing new information and learning skills. These skills form a unity but can be distinguished to be able to create learning situations in which all four components can be trained. Comparative studies of numeracy, for example YALS, NALS and IALS, showed that numeracy is of international concern in western societies. In IALS, on average, about 35% of the population in 12 participating countries achieved only at levels 1 and 2, out of five levels.

This means that about one-third of the adults in this survey performed below the supposed minimum of level 3 to effectively participate in personal, societal and work situations. Contrary to common belief, technological tools like calculators and computers cannot help in reducing this problem. Numerate behavior is shown when people are able to think and communicate mathematically, to draw conclusions from mathematical reasoning and to manage mathematical situations. In many situations this cannot be done with a calculator. People need to know what to do in mathematical situations, how to take hold of mathematical problems, when and how to do computations, if at all, and in which situations a calculator can be useful. For example, to compute 10% discount, they need to know what to compute and how to do it with a calculator before they can start using the calculator effectively. Insight into mathematical concepts and computations cannot be replaced with a calculator. That

is where most semi-numerate people fail. Despite the developments in the field of numeracy education to adults, the concept of numeracy is hardly known in education across countries, in the Netherlands neither. In many countries a word for “numeracy” does not even exist in the local language.

In the Netherlands the word numeracy [“gecijferdheid” in Dutch] is only used in academic discussions. In the Dutch adult and vocational education the word “mathematics” is used, which may recall memories of (negative) school experiences in earlier days. In Dutch adult and vocational education it would at least be better to use the words “functional mathematics” to indicate a difference with school mathematics. In some other countries, such as the U.S.A., the U.K. and Australia, the word numeracy is more commonly used in adult education, often interchangeably with the concept of “quantitative literacy” and “mathematical literacy”. In those countries numeracy courses attained an official place in curricula for adult education and indicate a difference with school math programs. In general, however, the importance of numeracy for adults in contemporary society is still underestimated, especially in adult education. For instance, the fact that the number of dropouts in Dutch vocational courses is still about 50% is often ascribed to the lack of literacy and problem solving skills of learners, but the possible link with a lack of numeracy skills has not yet been made.

***What mathematical content should be offered to adults in ABE to be equipped for the future?***

The answer to this question is mainly based on Steen’s broad ideas about quantitative literacy for the contemporary and future society (Steen, 1990). However, practical constraints force us to make choices and to restrict the mathematical content of a numeracy program in adult basic education to a minimum. Numeracy skills may differ per person and depend on the individual’s capacities, needs and wishes. The actual mathematical knowledge and skills people have acquired, as part of numeracy, are often determined by personal, societal and work-related demands. However, there should be a common set of basic skills that could serve as the minimum level from which adults can build on independently, depending on their individual goals, needs and wishes. Therefore a distinction was made among elementary, functional and optimal numeracy. In general, the elementary level provides such a basis.

To make this distinction operational for adult education it is necessary to determine what mathematical content would be the basis (the elementary level of numeracy) to build on in further education and vocational courses (functional numeracy). In some countries, for instance in Australia, the U.S.A., U.K. and the Netherlands, a start was made by the development of a coherent system of adult and vocational education.

A precondition for composing a mathematical program is that the content consists

of an integrated set of useful mathematical activities that focuses on functional mathematical knowledge and skills (learning-for-doing). Dossey (1997, p.46-47) describes such knowledge and skills as the “walking around quantitative skills we would expect of almost any citizen”. For such “walking around skills” adults need to have acquired a coherent set of functional mathematics that can serve as a tool in their everyday life situations and as a basis for further learning. The basic idea for such a set was found in Steen’s (1990) elaboration of quantity and number, dimension and shape, pattern and relationship, data and chance, and change. Steen describes the future world within these five broad fields of mathematics. His fundamental ideas set a broad range of mathematical concepts and activities for numeracy for the present and the future world. He considers these fields as integrated fields but they may be distinguished because of educational purposes. His basic idea is not to separate them in sub-topics but to integrate sub-topics into these overarching ideas.

To make his ideas operational for educational purposes and to develop numeracy programs these ideas will have to be explicated in content and skills recognizable for teachers and learners. In a numeracy program for adult basic education we must restrict the mathematical content to a minimum because of time-constraints. This means that it at least should include familiarity with numbers and doing simple operations with addition, subtraction, multiplication and division, insight into simple ratio problems and proportion, insight into benchmark fractions, decimals and percents and doing simple operations with them, using measurement units, elementary notions of shape and dimension, and reading and understanding simple data. It was discussed that learning through context-based tasks may help adults to make their mathematical knowledge and skills functional and recognizable in their real life situations. The use of a calculator and computer is emphasized in addition to mental math and to doing functional computations on paper. Such tools may help learners to compensate for lack of algorithmic procedures, provided that their computations are based on insight. Furthermore we argued that numeracy education for adults in adult basic education might want to focus on “math-as-a-tool” rather than on “math-for-knowledge”. Only functional mathematics can lead to functional numeracy. Numeracy courses should offer functional mathematics that is carefully structured, evaluated and adjusted to new developments at regular times. It should not only focus on mathematics that has already been developed but should also help to create an open mind for technological developments in the near future, which may include new mathematical demands. This is necessary to be equipped for the future.

### ***How do we assess the learners’ mathematical knowledge and skills when they enter ABE?***

In the second sub-study we described the literature study concerning this question in

order to set goals and criteria for assessment in adult basic education. Starting points were found in studies of assessment in school mathematics, particularly in De Lange's five criteria for good assessment of school mathematics (De Lange, 1987), the NCTM standards (1985), in Romberg's and Lajoie's study of authentic assessment (Romberg, 1995, Lajoie, 1995), Van den Heuvels' study of assessment in Realistic Mathematics Education (Van den Heuvel, 1996) and in Van Eerde's study of diagnostic assessment (Van Eerde, 1996). For adult education, Cumming and Gal (2000) make a distinction among assessment goals for the learner, the curriculum and for program evaluation. It was noted that the purpose of assessment in ABE is threefold:

- keep track on the learners' progress;
- evaluation of the program concerning goals, content and planning;
- evaluation of the program concerning reporting and accountability for funds.

Based on the studies mentioned above six goals could be set for assessment in adult basic education:

- 1 Learn more about the mathematical knowledge and skills adults have acquired when they enter ABE in order to determine what needs to be learned and to place them in the right courses.
- 2 Learn more about adults' problem solving procedures in order to improve instruction.
- 3 Learn more about adults' numeracy skills to be able to fine-tune educational programs to their needs and wishes.
- 4 Monitor and document the individual learner's progress in the course of the numeracy program in order to guide the learners through their own learning routes and to prevent learning problems and drop-out.
- 5 Be able to evaluate numeracy programs in order to improve numeracy education in general.
- 6 Enable policymakers and program developers to adjust policy and numeracy programs to new demands and developments in the labor market and in personal and societal life.

Consequently, criteria for assessment tools could be derived:

- 1 Numeracy assessment in ABE should be done in an appropriate way for learners in ABE.2
- 2 Assessment should enable adults to show what knowledge, skills and procedures they have mastered when they enter ABE, rather than what they do not have.
- 3 Numeracy assessment in ABE should provide insight into mathematical procedures and problem solving.
- 4 Placement tests in ABE should reflect the goals, content and levels of the math

curriculum so that adults know what they can expect during the course and can be placed in right course.

- 5 Numeracy assessment in ABE should allow second-language learners to apply the mathematical procedures and algorithms that they learned in their home countries.
- 6 Text used in a paper-and-pencil math test should not hamper second-language learners to take a mathematics test.

We argued that placement assessment for learners in ABE should be done in the way that is most appropriate for every adult in ABE and that yields qualitative information. Merely correct-incorrect scores and a proficiency score for level placement are not sufficient. Good assessment examines the learners' competencies. A good placement test offers a broad set of tasks on different levels that can identify the learners' mathematical knowledge and procedural abilities to prevent misplacement and drop-out and to acquire information for learning and instruction. It enables learners to show their mathematical thinking and reasoning, procedures, computation and notation systems in a constructive way.

The test can be organized in an adaptive way so that testing can be done as efficiently as possible and so that people will not have to do the entire test. An oral interview or a paper-and-pencil test, if carefully composed, often yields the best information. For learners in literacy courses oral interviews must be considered. Learners working on higher levels can take a paper-and-pencil test. The argument that such tests take too much time for teachers is offset by the qualitative information that can be acquired keeping in mind that the information that has not been acquired at the start of a numeracy course must necessarily be acquired later on during the course. Computer adaptive tests can be useful for quick scans in specific situations and for formative and summative assessment.

More research is necessary to examine how to organize assessment so that it can be as efficient as possible yet result in the best qualitative information. The qualitative information acquired from the placement assessment is necessary to fine-tune numeracy courses to the actual wishes and needs of the learners and to provide information about learning and teaching for ABE teachers. In general, a well-organized system of placement, formative and summative assessment is necessary to document the learners' progress but also for evaluation of numeracy courses and for accountability to stakeholders.

### ***What mathematical knowledge and skills have adults acquired when they enter ABE?***

To acquire more qualitative information about actual mathematical knowledge and skills of adults in ABE when they enter a numeracy course, we examined a group of

32 second language learners in an ABE learning center near Utrecht in the Netherlands.

For this field study the In Balance placement test (IB) and the Cito placement test (Cito) were used. The Cito test is a standardized test, validated on a sample of about 1200 respondents in ABE in 1993 (Straetmans, 1994). The Cito test was used to be able to compare the IB quantitative results with an independent test. The IB test provided a lot of valuable qualitative information about the learners. The group of  $N = 32$  was comprised of 11 men and 21 women. The Cito test provides scores on a continuous scale in three levels. According to the Cito test results, about 75% of the learners achieved at the beginning of level 2 and about 25% performed at level 1. Similar results were achieved on the IB test. Based on the numeracy level classification described in this study, it means that these learners mainly function on the elementary level of numeracy. In general it can be said that these learners had acquired only very limited mathematical skills.

The average score on all five main fields in the In Balance test (number and basic operations, proportions, measurement and dimension, money and data) was 56% correct. On the Cito test the average was even 50% correct. The highest average score on the IB subtests was on basic operations, 70% correct. The lowest average score was on proportions, 45% correct. The lowest average score of all subtests was on the percent items, within the field of proportion, only 15% correct.

The qualitative analyses showed that most of the learners (about 80%) can solve simple counting, addition and multiplication problems. In general the learners prefer doing algorithms to mental calculation, though the performance on the actual algorithm tasks are low (45% correct). For more complex context tasks concerning basic operations the percentage of correct answers decreases to about 40%. Estimation and mental computation are the least favorite. Learners tend to do precise computations. This was in particular striking with money tasks.

Though most money tasks were designed so as to encourage estimation as in real life situations, most learners tend to solve such tasks by doing precise computations through algorithms. The results for money tasks were about 50% correct. This may indicate that these adults have only acquired minimal skills to handle money tasks in real life situations, or cannot transfer real life related solutions to tasks in school situations.

In the field of proportions, fractions and percent the learners show a 75% correct score on simple proportion tasks related to recognizable real life issues, e.g. comparing the length of a car with the length of a bus. The percentage correct decreased enormously at simple tasks pertaining to benchmark fractions (30% correct score) and percent (only 15% correct score). For measurement, including decimals involved in the metric system, the results on the placement test show that about 80% of the learners can do simple tasks related to applying measurement in real life situations. When comparing measures within the metric system the percentage correct

decreases to just over 50%. When doing formal computations with given measures on paper, this percentage decreases further to 20%. Only four learners are able to compute the area of a floor with the help of a map of the floor. For reading and understanding data in graphs we come to similar conclusions. Learners are able to read simple line and bar graphs related to everyday life issues, like reading a temperature graph (about a 75% correct score). Indicating a quarter in a pie chart leads to a 50% correct score and understanding a more complex bar graphic about average sales of cars in one year yields only about 10% correct answers.

Given these results, we may wonder if these learners are able to benefit from their skills in everyday life. It may also be questioned how functional and how flexibly applicable their skills are with respect to the necessary skills that would enable them to solve mathematical problems in work and in vocational courses. Most learners showed that the skills they had acquired were limited to only using traditional computation procedures, i.e. algorithms, often completed without any insight. Such procedures were in particular striking with money computations and when doing estimation. Rounding amounts in money computations after having computed them precisely was seen as doing estimation. The percentage correct for rounding and estimation items was 20% on average. Only a few learners showed insight into their own creative, more informal, solution procedures, mainly in proportion and measurement tasks.

These results are understandable if we consider that many learners only received very traditional mathematics education in their home countries. The above supports the observation that second language learners need time, not only to learn a second language but also to get used to a different system of learning and teaching in adult education in a new country. In the Netherlands, particularly, they also need to adjust to new ideas concerning the learning of mathematics.

In adult basic education it means that they have to overcome three main problems in a short period of time when preparing for vocational education and for work. These problems should be considered when numeracy programs are developed, but should not hinder the learners from taking a numeracy course. The observation may even emphasize the importance of numeracy courses alongside the literacy courses at the basic level.

Contrary to the common assumption in vocational education, it takes more than just mastery of the second language to succeed in vocational courses. Though the learners in this study are from only one common group in ABE they may be seen as representatives of the learners in ABE in general in the Netherlands because of the placement criteria and because of their results on the Cito test. Since there are about 50,000 learners in ABE and at least 1,5 million people at this level in general in the Nether-

lands (given the results of the IALS study), this group of adults should be of more political concern.

***What way of learning and teaching mathematics could be appropriate for adults in ABE?***

A main part in this research was a study of ways of learning that could be appropriate for learners in ABE. Answers to this question are based on literature about learning in general, the learning of adults specifically and on studies about mathematics education, in particular Realistic Mathematics Education. These theories were connected with teaching experiences in adult basic education concerning the learning of adults. Andragogical starting points were formulated for adult education in general:

- 1 Adults are free to learn.
- 2 Learners and teachers are equal partners in learning situations.
- 3 Adults' own experiences are the basis for learning.
- 4 Authentic materials should be used as instruction materials in school learning situations.
- 5 Learning takes place by interaction and reflection.
- 6 Learning in adult education aims to lead to functional knowledge and skills.
- 7 Adults direct their own learning

Based on these starting points it can be concluded that learning mathematics in ABE must focus on math-as-a-tool and hence on learning-for-doing and learning-by-doing, i.e. learning-in-action. However, mathematics education is too often still a theoretical event that happens in classrooms and consists of learning from books. Greeno (1999) argued - and this can be confirmed by several other studies about learning at work and in other out-of-school situations - that informal learning in the course of action yields the best functional knowledge and skills. This indicates that mathematics education in ABE should focus more on real learning-by-doing with authentic materials. However, it should not only consist of learning-by-doing and learning-in-action because of the risk that such functional knowledge and skills may also yield context-bound and partial knowledge and skills.

Learning in ABE must focus on context-based knowledge and skills, which means that it is better flexibly applicable in different situations. Ways of learning mathematics were elaborated along the starting points of Action Theory, Constructivism and Realistic Mathematics Education (RME). Though these theories originally evolved as theories for the cognitive development of children, adult education can benefit from their results. From an adult perspective, they offer many possibilities to look at including to examine what adults could have missed in their youth concerning the development of mathematical concepts. Based on this perspective, strategies can be outlined for learning mathematics in adult education. Action Theory and RME provided four action levels for learning mathematics in ABE:

- doing informal manipulations in actual real life situations;
- using representations of real objects and situations;
- using schematic representations;
- using symbols and formal/functional operations.

Adults have often acquired a mix of mathematical knowledge and skills. To adjust, correct and expand their knowledge and skills they will need to go through all four levels, often at the same time. Hence, the action levels cannot be seen as real different levels, but more as intertwined fields where people go through from different angles and in different directions. However, they need to go through all fields to build complete concepts. Constructivism and RME offer a frame of reference for the analysis of the learning process itself. In ABE problem based learning has been advised as a main way of learning. The six steps in problem solving offer possibilities for learners to learn manage mathematical situations in real life but they also enable them to analyse their own ways of learning. Within this process three elements can be distinguished:

- 1 Through problem solving learners become aware of learning process itself (*what*).
- 2 During problem solving learners may want to emphasize the quality of their learning (*why*).
- 3 When doing problem solving learners learn how to organize the learning process (*how*).

Through the what-why-how process learners learn to direct their own learning processes themselves and this is what they need for independent learning in real life situations. Problem-based learning also offers possibilities to create learning situations in which mathematical concepts and actions are integrated. Mathematics in real life situations never occurs as separate mathematical tasks. Situations are often complex and the mathematics in it is hidden. Contexts in mathematics education should be real or derived from real life situations. They must offer possibilities to solve mathematical problems in multiple (informal) ways.

Basic operations, for example, should be learned in a connected way. People need to know when they can use addition, subtraction, multiplication or division and what to do if they cannot do subtraction, for instance. Contexts are the main ingredients for learning mathematics in adult education. They must be structured carefully, using the complexity factors, as discussed in chapter 7, as the main factors and the four action levels as the second ones. In addition, context-free tasks can help familiarize learners with characteristics of numbers. Knowing such characteristics is necessary for estimation and mental math. When doing computations and mathematical operations adults are free to create their own ways of solving problems and to

develop their own individual, functional notation systems. Such functional procedures and notations are almost always based on insight and support their individual thinking in specific situations. Hence they are often better usable than standard procedures like traditional algorithms.

***How to develop a program for functional numeracy education in Adult Basic Education that prepares adults to be equipped for the future?***

The answer to this question is based on the answers to the previous questions and on experiences with the In Balance learning materials. Some of our experiences were showed in the exemplary teaching experiment in the third sub-study. In the last part of this study it was argued that numeracy courses should be built on the four components of numeracy. It is advised to build the first component - mathematical knowledge and skills - on integrated strands, benchmark learning, integrating visual models and action levels.

The other three components - learning to manage a mathematical situation, acquiring new information in real life situations, and developing learning skills - can be addressed by problem solving. In the theoretical study we discussed that Action theory and RME lay the foundation for learning functional mathematics. Constructivism and RME offer ingredients for the analysis of the learning process itself. Such analysis can be done by applying the what-why-how questions. Thus the focus within learning mathematics may switch from analysing the learning process itself to focusing on how to manage a problem and on the quality of the problem solving procedure. In this way adults learn how to manage mathematical problems in real life situations.

Benchmark learning is the core for creating a concise but complete program in ABE. Learners are able to go through all important subjects in a short time and to develop basic computation skills based on benchmarks. Benchmarks may help adults to find the core relations between different mathematical concepts like proportion, fractions, decimals and percent and within the metric system. They may also help develop touchstones or points of reference for their computations and for mental math and estimation.

The use of a calculator is strongly advised, especially at the lower levels, to compensate for lack of procedural skills. The benchmark approach is an effective way of learning in ABE, because it offers a complete program on all levels and can be extended into more detailed procedures and computations at the higher levels. The benchmark theory as elaborated in this study requires further research to extend and further develop these basic ideas. Integrating visual models are the links between mathematical concepts and across strands. They, in combination with manipulations, help learners visualize their thoughts in real life situations.

Manipulation and visualization in combination with communication enable them to

develop complete concepts. It also enables second language learners to overcome language problems when learning mathematics. Though from a constructive point of view we strongly encourage teachers to have their learners develop their own visual models and to use models they already have developed in their own idiosyncratic way, a few core visual models, like a proportion bar, the block model as a multiple proportion bar, a number line and a pie chart, should be offered to help them getting used to this approach. Blank models of these can be used as computation models. Based on such core models learners can expand their own individual mental models. Further research into the basic ideas of integrating visual models is strongly advised. Specific research settings should be created to study the function of integrating visual models across strands and the benefits they could have for second-language learners.

Problem solving is recommended as an approach to help learners develop skills for managing mathematical situations and for cooperative and teacher-free learning. The six steps of problem solving and the what-why-how procedure, as discussed in the third sub-study, can help to develop skills that are necessary for independent learning in real life situations and are the core of lifelong learning. More research is necessary to develop such programs in practice. Time constraints are the main problem in adult education, and hence also in adult basic education.

Many numeracy courses in adult education have a very short duration, often limited to about 100 hours, compared to about 600 hours for learning a second language and becoming familiar with the Dutch society. While this may not be a problem for learners on higher levels, but for learners in ABE the time for numeracy courses is often too short. They need a full basic program to acquire a set of adequate skills necessary for further education and work. The learners in this study are all on a very low mathematical level. We may question whether such short courses will enable these learners to move on to courses in further and vocational education. Besides, in most education programs numeracy (or mathematics) courses are not an obligatory part of the program. As long as this situation continues, under-schooled newcomers will have problems in vocational courses and in work. Mastery of the second language plus sufficient numeracy knowledge and skills, in combination with being familiar with the new society people live in, are preconditions for successful learning in vocational education.

## **8.6 Recommendations for Future Research**

In this study we have explored the field of learning mathematics by learners in adult basic education within the larger frame of developing numerate behavior. The study provides a lot of qualitative information about the mathematical knowledge and skills of adults in ABE. Based on existing theories about the learning of adults and about learning mathematics we have tried to create a theoretical foundation for Functional Numeracy Education to adults that focuses on learning functional math-

ematics, applicable in real-life situations and managing mathematical real-life situations. As part of the learning process learners learn how to direct their own learning process to be able to acquire mathematical information in real-life situations.

Though a start has been made and a lot of information was acquired about numeracy in ABE, this study requires an immediate follow-up because we need more information about adults' actual numeracy skills and how they learn mathematics. A few selected topics are:

- 1 The proposed theory and program for Functional Numeracy Education (FNE), as elaborated in this study, are based on many years of teaching experience, studying theories and developing materials. The results of this study indicate that an FNE program based on these starting points can be very effective, but evaluation of such a program over a longer time frame is necessary. Within this study two topics can be emphasized as interesting research subjects: benchmark learning and functional procedures.
- 2 In order to measure the effectiveness of the FNE program, research is necessary into how (under-schooled) adults actually manage mathematical situations in real life. Such could be set up based on topics in the FNE program in an ABE learning setting in combination with how similar topics are carried out in real-life situations, among which work situations.
- 3 Lack of numeracy skills of learners in the Dutch ABE who want to move on to further education and to vocational courses, may cause that these learners do not succeed in completing these follow-up courses. Evaluation of numeracy courses in ABE is necessary to measure the gap between the numeracy skills learners have acquired when they have completed ABE programs with the required numeracy skills for programs in further and vocational education.
- 4 Results of international comparative studies, like the IALS and the coming ALL survey, should be analysed on possible consequences for adult education. For ABE it is desirable to compare numeracy programs in an international research setting. The learners in this study represent only one common learners' group in ABE in the Netherlands. Despite this, their results on the placement tests and the learning experiment may indicate on a wider level that numeracy in ABE needs careful attention. These adults are on such a low level of numeracy that they will have little chance of success in vocational courses and in work. In addition we must be concerned about the 36% of the entire Dutch adult population, native and foreign born, who achieved only level 1 or 2, out of five levels, on the quantitative literacy scale of the IALS survey. About 1.5 million people achieved only level 1. This means that innumeracy, and illiteracy as well, are still of great concern. Our current technological society demands a high level of numeracy skills. It continuously develops further and the gap between the top of a numerate society and the lower end of literacy and numeracy is increasing.

In addition to the above research topics we recommend that:

- 1 Adult learning centers work more actively on the acquisition of potential learners and on offering low-threshold programs and courses in which they can participate.
- 2 Teachers in ABE have acquired professional skills to support and guide learners in their learning of functional mathematical knowledge and skills, e.g. based on the FNE theory.
- 3 Learning materials have been developed to effectively help these learners.
- 4 Literacy and Numeracy are topics on international policy agendas.

## 8.7 Concluding

In the introduction this study was characterized as exploratory, descriptive, qualitatively analysing, theory building and developing. We have tried to give the learners in adult basic education a face and to describe their competencies and their needs. We have also tried to show the importance of numeracy and numeracy courses for these learners, in particular in the frame of lifelong learning. This study shows that numeracy in ABE needs professional attention. We hope this study encourages program developers and teachers in ABE to develop effective numeracy programs that lead to functional numeracy. We also hope that this study encourages other researchers to take the thread and to further develop the theoretical ideas set out in this study. In his book “Mathematics and Democracy, the Case for Quantitative Literacy” Steen (2001, page 108) argues in the epilogue

“Counting people, counting dollars, and counting votes are part of the numeracy of life. Unlike the higher mathematics that is required to design bridges or create cell phones, counting appears to require only rudimentary arithmetic. To be sure, when large numbers, multiple components, and interacting factors are involved, the planning required to ensure accurate counts does become relatively sophisticated. So even though the underlying quantitative concepts are typically rather elementary - primarily topics such as multiplication, percentages, and ratios - the mental effort required to comprehend and solve realistic counting problems is far from simple.”

He ends the book with the words:

“Numeracy is not the same as mathematics, nor is it an alternative to mathematics. Rather it is an equal and supporting partner in helping students learn to cope with the quantitative demands of modern society. Whereas mathematics is a well-established discipline, numeracy is necessarily interdisciplinary. Like writing, numeracy must permeate the curriculum. When it does, also like writing, it will enhance students’ understanding of all subjects and their capacity to lead informed lives.” (Steen, 2001, page 115).

With this study we have tried to pave a way to help adults in ABE learn to cope with numeracy demands in real life.

## References

- Cito (1996). *Intake toets Rekenen en Wiskunde* [Placement test Mathematics] Arnhem: Netherlands, Cito.
- Cito (1996). *Nivor-1 toets, onderdeel lezen* [SLL, level-1, reading] Arnhem: Netherlands, Cito.
- Cumming, Joy & Iddo Gal (2000). Assessment in Adult Numeracy Education: Issues and Principles for Good Practice. In: I. Gal (Ed.). *Adult Numeracy Development: Theory, Research, Practice*. Cresskill, NJ, US: Hampton Press inc.
- Dossey, John A. (1997) National Indicators of Quantitative Literacy. In: Steen, Lynn Arthur (Ed.). *Why Numbers Count. Quantitative Literacy for Tomorrow's America*. New York: College Entrance Examination Board.
- Eerde, H.A.A. van (1996). *Kwantiwijzer, diagnostiek in reken-wiskundeonderwijs*. [Kwantiwijzer, diagnostics in mathematics education] Tilburg: Zwijzen, Netherlands.
- Greeno, James G., Penelope Eckert, Susan U. Stucky, Patricia Sachs & Etienne Wenger (1999). Learning in and for Participation and Society. *How Adults Learn*. Proceedings of a Conference held April 6-8, 1998, Georgetown University Conference Center, Washington, DC. Sponsored by the Organization for Economic Cooperation and Development and U.S. Department of Education.
- Groenestijn, Mieke van, Sjaak Joziassse & Piet van Rheenen (1994-1997). *In Balans. Realistisch rekenen-wiskunde voor volwassenen*. [In Balance, a Series of Realistic Mathematics Education to Adults]. 's-Hertogenbosch, Netherlands: Malmberg, bv.
- Groenestijn, Mieke van (1996a) *In Balance. Background information to the series*. 's-Hertogenbosch, Netherlands: Malmberg, bv.
- Groenestijn, Mieke van, Sjaak Joziassse & Piet van Rheenen (1996b). *In Balans, instaptoets* [In Balance, Placement Test]. 's-Hertogenbosch, Netherlands: Malmberg, bv.
- Heuvel-Panhuizen, M. van den (1996). *Assessment and Realistic Mathematics Education*. Utrecht, Netherlands: Freudenthal Institute.
- Houtkoop, W. (1999). *Basisvaardigheden in Nederland* [Basic Skills in the Netherlands] (Dutch Report of the IALS Survey) Amsterdam: Max Goote Kenniscentrum, Netherlands.
- Kamp, M. van der & J. Scheeren (1996). *Functionele taal- en rekenvaardigheden van oudere volwassenen in Nederland*. [Functional literacy- and numeracy skills of older adults in the Netherlands] (Report of IALS results in the Netherlands in particular regarding older adults). Amsterdam: Max Goote Kenniscentrum, University of Amsterdam.
- Lajoie, Susanne P. (1995). a Framework for Authentic Assessment in Mathematics. In: Romberg, Thomas A. (Ed.) *Reform in school Mathematics and Authentic Assessment*. State University of New York Press, Albany.
- Lange Jzn, Jan de (1987). *Mathematics, insight and meaning*. Utrecht: Netherlands, OW&OC, University of Utrecht, Freudenthal Institute.
- Romberg (1995). Issues related to the Development of an Authentic Assessment System for School Mathematics. In: Romberg, Thomas A. (Ed.) *Reform in school Mathematics and Authentic Assessment*. State University of New York Press, Albany.
- Steen, Lynn A. (Ed.). (1990). *On the shoulders of Giants*. MSEB, National Academic Press, Washington, D.C., USA.
- Steen, Arthur Lynn, Ed.). (2001). *Mathematics and Democracy. The Case for Quantitative Literacy*. National Council on Education and Disciplines (NCED), USA.
- Straetmans, Gerard (1994). Een intake-toets rekenen/wiskunde voor de basiseducatie. [A Placement test for mathematics in Adult Basic Education]. *Tijdschrift voor volwassenen educatie, 1994, number 4*.